

KDD022 - Multi-dimensional Account-based P&L Reporting

Status	Approved
Owner	TAMIOLAKIS-ext, Emmanouel
Stakeholders	HOULDER-ext, Christopher MADJARIAN, Gilles Stecik, Joseph Harris, Samantha Matos, Roberto

Issue

This design decision document addresses the need for Syensqo to have a comprehensive profitability analysis through multi-dimensional account-based Profit and Loss (P&L) reporting to:

- Support decision-making
- Ensure compliance
- Provide real-time insights into business performance.
- Utilize universal ledger as the central data pool.

The current Profit & Loss (P&L) reporting system lacks uniformity due to different reporting characteristics in the two primary data entry systems, WP1 and PF1, as well as the old system architecture that relies on secondary data and aggregate tables. As a result, Syensqo depends on numerous satellite reporting systems and custom solutions to provide uniform, multi-dimensional profitability analysis. A decision is needed to choose between account-based margin analysis and costing-based profitability analysis (current solution) to address these deficiencies. It is important to note that the purpose of this design decision document is not to determine the P&L structure or the dimensions/characteristics, as these will be addressed in the detailed design phase. This decision aims to fulfill the business need for detailed, uniform, real-time profitability insights that align with the trial balance and ensure accuracy.

Recommendation

Implement Margin Analysis utilizing Account-Based Margin Analysis instead of Costing-Based Analysis.

- This approach will enhance integration with financial accounting by directly consuming data from the transactional table.
- Provide real-time data access, and leverage the capabilities of Universal Ledger. e.g Ledger approach capabilities like P&L by ledger and currency type.
- It will improve online analytical processes by reducing the need for satellite system reports and possibly systems. (e.g Finance dashboards, BW, BI, QlikSense/QlikView, etc)
- SAP is directing its innovation and support efforts towards account-based margin analysis, potentially limiting future enhancements and support for costing-based CO-PA

Background & Context

With evolving business complexities and the need for granular profitability insights, traditional reporting mechanisms fall short. Account based Margin Analysis offers a robust solution for detailed profitability analysis by integrating with the Universal ledger, thus eliminating reconciliation issues and enabling multidimensional reporting directly at the source.

Technical Overview of the S4 Account-Based Margin Analysis

Margin Analysis leverages the Universal Journal (table ACDOCA) to integrate financial and managerial accounting data into a single source of truth. The Universal Journal consolidates data from various submodules such as General Ledger (FI-GL), Asset Accounting (FI-AA), Material Ledger, and Controlling (CO). This integration ensures that all financial transactions, including those relevant for profitability analysis, are stored in a single table (ACDOCA), the so-called Universal ledger which includes detailed line items for each transaction. In the Syensqo framework, this means that the P&L can be prepared directly within the data entry system, organized by activity, and reconciled with the trial balance.

Account-based margin analysis leverages the same dimensions and characteristics available in the Universal Ledger. These include company code, profit center, segment, and cost center, as well as critical sales-related dimensions such as customer, product, and sales channels. *The complete set of characteristics will be defined during the detailed design phase.* As transactions occur, data is instantly updated in the Universal ledger, providing real-time insights without the need for batch processing or data reconciliation with the trial balance. Finally account based Margin analysis can make use of the new financial planning capabilities directly in S4 like the Import Financial Plan Data app.

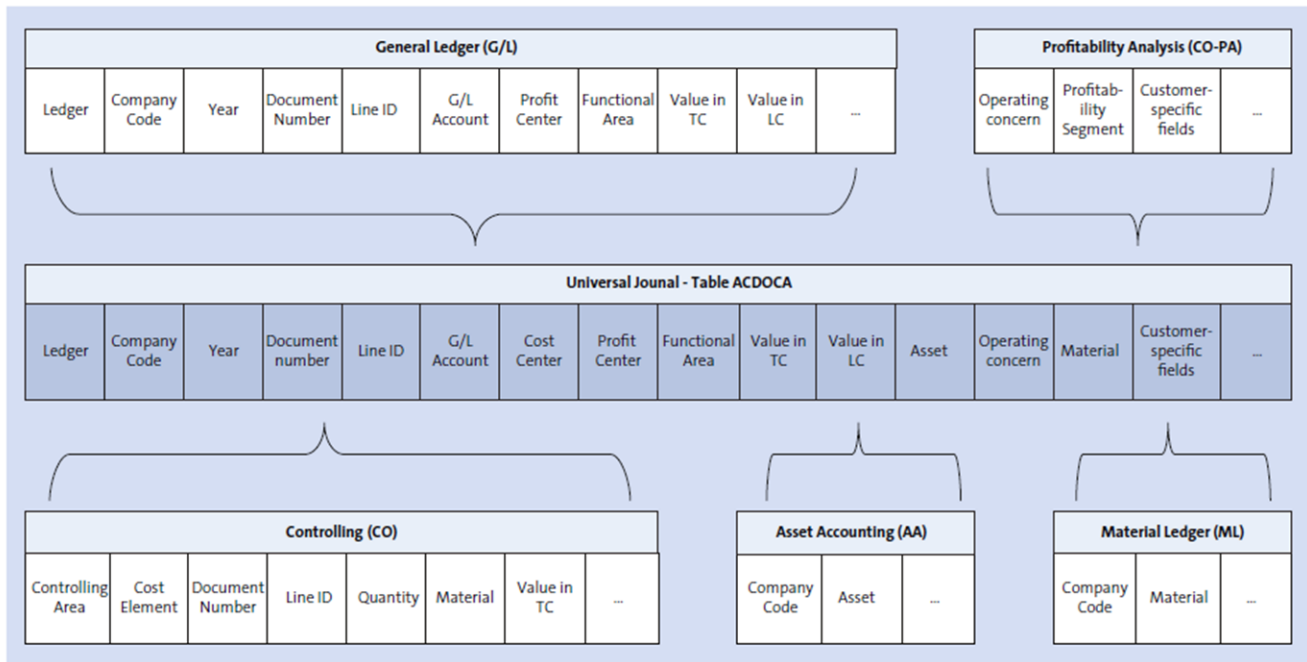

Enhanced Reporting Capabilities:

- **Multidimensional Reporting:** Users can analyze profitability across multiple accounting, controlling and sales dimensions such as, Ledger, product, customer, region, business unit etc.
- **SAP Fiori Applications:** Account-based CO-PA leverages SAP Fiori applications that allow for real-time data slicing and dicing. It is worth mentioning here Fiori apps like: P&L plan/actuals, Market Segments - Plan/Actual, P&L - Plan/Actual YTD.
- **SAP BW/4HANA reports:** Many previously existing SAP BW info-structures are now available in the Fiori user environment. With the concept of the logical data warehouse approach, SAP BW/4HANA eliminates the data replication, storage, and the need to move data from the organization's applications
- **Traditional SAP GUI Reports:** For users familiar with the classic SAP interface, traditional reports are available that can utilize the same real-time data from the Universal Ledger.
- **Custom fields can be added to the Universal Journal to capture additional profitability characteristics specific to Syensqo's business needs or units of measure. If any requirement for custom fields exist must be carefully planned and discussed during the detailed design. Once custom fields are added to the Universal Journal, they cannot be deactivated. This requires careful planning and long-term consideration.**

A new concept that Account based - Margin analysis introduced is the use of Semantic tags in reports. Syensqo will have the flexibility to define the financial reporting items, such as revenue, COGS, labor, sales deductions, recognized margin, and so on, as semantic tags. The report creator then uses these semantic tags in the various margin analysis or financial reports instead of defining them each time a query is built. A basic example on the use of semantic tags are the tags assigned to general ledger accounts under the operational chart of accounts and defined for financial statement versions (FSV).

Here is a straightforward example of how account-based reporting functions in practice. Please note that the P&L structure provided is solely for illustrative purposes and should not be interpreted as representative of Syensqo's P&L.:

P&L item	Amount	Source Account	Source object
Revenue			
Sales Revenue	1200	Primary accounts	Billing document
Service Revenue	300	Primary accounts	Billing document
Total Revenue	1500		
Cost of Goods Sold	800	Primary accounts	Goods issue
<i>Raw Materials</i>	400	Primary accounts	Goods issue split document
<i>Direct Labor</i>	200	Primary accounts	Goods issue split document
<i>Utilities</i>	100	Primary accounts	Goods issue split document
.... <i>other</i>	Primary accounts	Goods issue split document
Gross Profit	700		
Operating Expenses			
Selling Expenses	100	Secondary account from allocation to Margin analysis	Cost center or WBS
Administrative Expenses	150	Secondary account from allocation to Margin analysis	Cost center
R&D Expenses	50	Secondary account from allocation to Margin analysis	Cost center or WBS
Total Operating Exp	300		
Operating Profit	400		

As transactions occur, data is instantly updated in the Universal Ledger, providing real-time insights without the need for batch processing or data reconciliation.

Performance Optimization

Elimination of Redundancies, by maintaining a single source of truth, data redundancies are eliminated, significantly improving data accuracy and reporting speed.

Assumptions

- Syensqo will implement S/4
- The data volume will be substantial, necessitating efficient data processing capabilities
- Standard SAP Fiori apps, customer CDS views and classic transactions, like KE30 will be available for reporting.
- There may be a need for customization to fully leverage all reporting capabilities. Like custom CDS views. *Core Data Services view: Is a tool used in SAP software to create and manage database queries. It is like setting up a customized lens through which you can see and use your data more efficiently.*
- Combined profitability analysis will be assessed during detailed design phase

Constraints

- According to the [scope Note](#) for Universal parallel accounting, both the Costing based and Combined profitability analysis are not supported (Note: 3191636)
- COGS will be realized during goods issue for managerial accounting as well.

Impacts

New uniform dimensions/characteristics as well as new P&L structure will be defined during detailed design

Business Rules

- New dimensions/characteristics will be defined during detailed design to cover various dimensions such as product lines, geographies, and customer segments.

Options considered

Option A: Implement Account-based margin analysis

This option involves using the Universal Ledger that stores financial and managerial accounting data into a single source of truth. Account-based profitability analysis leverages the Universal Journal (table ACDOCA) to ensure that all financial transactions are stored in a single table. The use of SAP Fiori applications and traditional SAP GUI reports will allow real-time data access and analysis.

Option B: Implement costing based profitability analysis

This option involves using separate tables and value fields for profitability analysis, requiring reconciliation with the Universal Ledger. Costing-based profitability analysis focuses on deriving profitability data based on value fields, which may involve batch processing and data reconciliation efforts. While it can provide detailed cost-related insights, it lacks the seamless integration and real-time capabilities offered by account-based margin analysis in S/4HANA.

Evaluation

	Option A: Account based	Option B: Costing based
Integration	<ul style="list-style-type: none"> ➕ Ensures real-time reconciliation with Trial balance ➕ Seamlessly integrates with the Universal Ledger, providing a single source of truth for all financial transactions. This reduces the need for data reconciliation and ensures real-time updates. ➕ Supports advanced analytical capabilities, providing a comprehensive view of profitability that aligns with the Syensqo's strategic goals ➕ All revenue and cost of goods sold (COGS) postings are automatically assigned to the relevant profitability analysis characteristics in Universal Journal at the time of posting, so no reconciliation is required. 	<ul style="list-style-type: none"> ➕ Syensqo like many organizations are familiar with costing-based CO-PA, reducing the learning curve and leveraging existing knowledge and infrastructure ➖ Requires separate data sets and reconciliation with the Universal Ledger, introducing complexity and potential delays in data updates ➖ Groups revenues and costs according to value fields and applies costing-based valuation approaches. Data is recorded in a dedicated persistency apart from external accounting.
Reporting Capabilities	<ul style="list-style-type: none"> ➕ Supports multidimensional reporting with real-time derivation of reporting dimensions through SAP Fiori applications and traditional SAP GUI reports. (SAP BW /4HANA reports, SAP Analytics Cloud reports, SAP Fiori apps and classic reports (KE30)) ➕ Margin analysis is fully integrated with the Universal Journal and derives the appropriate characteristics on every journal posted to the Universal Ledger. ➖ Up to three units of measure and quantity fields are supported ➖ There may be a need for customization to fully leverage all reporting capabilities. Like custom CDS views. Core Data Services view. ➖ In the early versions of S4, statistical sales condition types (e.g special discounts) were not posted in account based margin analysis but in the current versions are supported. Nevertheless, the setup process for managing statistical condition types in account-based margin analysis is more complex compared to costing-based CO-PA, requiring careful configuration of multiple elements such as ledgers, account keys, and GL accounts. 	<ul style="list-style-type: none"> ➕ Costing-based CO-PA allows for the creation of custom value fields, offering flexibility to define and measure specific profitability metrics tailored to business needs. Statistical sales condition types are the best example of such case ➕ Several units of measure and quantity fields are supported ➖ Costing based CO-PA has only two standard reports, and the rest had to be built using COPA drilldown reporting tools (Transaction KE31). The two standard reports are Display Plan Line Items (Transaction KE23) and Display Actual Line Items (Transaction KE24). ➖ While capable of providing detailed cost-related insights, it lacks the comprehensive multidimensional reporting and real-time capabilities of account-based analysis. ➖ Usually, requires additional adjustments to reconcile with Trial balance.
Future compatibility	<ul style="list-style-type: none"> ➕ SAP encourages its customers to move to margin analysis, where all the innovation and investment are focused. 	<ul style="list-style-type: none"> ➖ SAP's strategic direction is less focused on costing-based analysis, potentially limiting future support and innovations.
Performance	<ul style="list-style-type: none"> ➕ Real-time data updates and elimination of redundancies improve reporting speed and accuracy, enhancing overall performance. 	<ul style="list-style-type: none"> ➖ Involves secondary processing and data reconciliation, which can impact reporting speed and data accuracy, leading to potential delays in profitability insights.

See also

File	Modified
PDF File Workspace Mail - Fwd_ KDD.pdf	Sept 30, 2024 by FALL-ext, Cheikh

Change log

Version	Published	Changed By	Comment
CURRENT (v. 44)	Sept 17, 2024 09:04	WENNINGER-ext, Sascha	
v. 43	Aug 30, 2024 10:37	TAMIOLAKIS-ext, Emmanouel	
v. 42	Aug 07, 2024 12:21	WENNINGER-ext, Sascha	
v. 41	Aug 05, 2024 14:11	TAMIOLAKIS-ext, Emmanouel	
v. 40	Aug 05, 2024 14:11	TAMIOLAKIS-ext, Emmanouel	
v. 39	Aug 05, 2024 10:28	TAMIOLAKIS-ext, Emmanouel	
v. 38	Aug 02, 2024 14:17	TAMIOLAKIS-ext, Emmanouel	
v. 37	Aug 02, 2024 14:16	TAMIOLAKIS-ext, Emmanouel	
v. 36	Aug 02, 2024 14:04	TAMIOLAKIS-ext, Emmanouel	
v. 35	Aug 02, 2024 06:30	WENNINGER-ext, Sascha	

[Go to Page History](#)

Workflow history

Title	Last Updated By	Updated	Status
-------	-----------------	---------	--------

There are no pages at the moment.
