

BW Industrial - EHS - Waste Management (entries / CADRI) /!\ Obsolete /!\



The new wiki link for this data flow is here:

[Technical Documentation - Waste Management Report](#)

Please update the doc there and no longer here.



- [General presentation](#)
 - [Objective of the application](#)
 - [Usage information](#)
 - [History](#)
- [Roles & Access](#)
 - [Roles and access](#)
 - [Authorization objects](#)
- [Dataflow overview](#)
 - [Functional and Technical rules on Workbench + Reporting](#)
 - [Rules & Explanations](#)
 - [Dependencies with other applications](#)
- [Data loadings](#)
 - [Info providers and objects loaded](#)
 - [Loading frequency](#)
 - [Average performance](#)
 - [Record Keeping](#)
- [Reporting](#)
 - [Queries End User Documentation](#)
 - [Main queries](#)
 - [Main functionalities](#)
 - [Broadcast](#)
- [Maintenance](#)
 - [Known bugs](#)
 - [Recurring procedure](#)
 - [Planned Evolution](#)

General presentation

Objective of the application

The functionality of Waste Management aims to use SAP system for optimizing the control of all relevant legal documents of waste management process, ensuring integrity, accessibility and traceability of all data and costs related to the process, and compliance with legal requirements.

The SAP module is installed and used on Solvay/RCS legacy systems.

The SVT reporting is now based on a BW solution.

Usage information

Around 2 users, In Latin America first. It be implemented in other countries in the future.

History

In 2016 it was implementyed as a pilot solution for Paulinia site, however this solution can be rolled out easily to any other Brazilian site, and even to any other Region.

For Paulinia operations SAP Environment is WP1

Today, in Paulinia we have one main user that is the Waste Administrator Management and one or two representatives per production unity. Also, not specifically, there are people that deals with transport and expedition, the purchase people and the cost control people.

Roles & Access

Roles and access

Role Code	Role Description	Explanation
ZR_RCS_CA_M5X	EHS - Waste Management	Menu access to transaction RRMX (bex analysis)
ZBI_RCS_EHS_A06	EHS - Waste Management	Access to InfoArea WASTE

Authorization objects

Authorization object	Explanation
C_PLANT	Restriction for plants in analysis
C_CNTRY	Restriction for country in analysis

Dataflow overview

Reporting documentation drive folder:

Functional Specification for Waste Management

1. WASTE MANGT. - ENTRIES CONTROL BW

Mapping for Waste Management

Functional Specification for Waste Management

WASTE MANGT. – BW CADRI REPORT

Mapping for Waste CADRI

Example of dataflow overview :

Template Application name DataFlow

Functional and Technical rules on Workbench + Reporting

Rules & Explanations

BW EHS Waste Management and CADRI

The goal of Entries Control Report is to provide a report that facilitates the control of waste generation by period and its posterior management at Paulinia site.

In order to control the generation of each waste by several generating areas of Paulinia and the subsequent steps to final disposition from the supplier, it is necessary to list all Entry Documents created in the period that were not deleted, and them to have the trace of each relevant document created during the process.

Waste Management processes are transversal processes that involves EHS (DG and Product Safety), RtR, PtP and OTC.

There are 2 main transactions in Waste process:

- Edit Entry Documents - WAE0X – that creates Entry Documents, wastes, stock entries and purchase Orders,
- Edit Disposal Documents – WAM0X – that manages the details of waste expedition and posterior disposal

Both types of documents – entry and disposal – have different types of status that are linked to their current process step.

There is a governmental license –CADRI- that controls the amount of waste that can be disposed by type of waste and by disposer in a defined period. Also for each waste there are 2 codes that must be informed CETESB and IBAMA CODES.

Also, there are 2 types of classification, one related to waste and its transport, that is the normal DG country classification. And the other is a country Waste Code related to its waste nature.

Summarizing the process at Brazil:

- 1- The generator representative creates an amount of waste in the system. The number of units is exact but the weight is estimated. The waste will be weighed only at the time that it is being issued, therefore the quantity in Kg is estimated until the expedition time.
- 2- The Waste Administrator release the Entry Document and define where the waste will be stored, transferring the quantity to the defined warehouse.
- 3- Waste Administrator defined the disposer and the transporter and creates the Disposal Document and the purchase request that is based in a preexistent contract. There is an automatic check regarding governmental license- CADRI- if there is no allowed volume, the process is blocked.
- 4- In the purchase request the Waste Adm informs the date expected to issue the waste. Back office team will create the purchase order. The purchase process is a subcontracting process. Therefore there is a mirror virtual material (ZDIE) linked to each waste material (ZUNB). The waste material appears in the purchase order as a component.
- 5- The logistic team creates the delivery by transaction ME2O, based in the purchase order. After the delivery creation, logistics team creates the shipment order and the expedition programing. If it is the case, all the usual process regarding DG goods expedition is followed.
- 6- In right date, the picking is done, the truck is loaded, the waste is weighed, NFe is created and the expedition is done. The waste delivered appears as in the supplier storage control.
- 7- NFe copy is sent to Waste Adm that input the data updating the Disposal Document. Also, the right weight value in KG is fixed by MIGO transaction in the stock.
- 8- After the effective disposal, the supplier (disposer) sends a destruction certificate and the related invoice to Waste Adm. The weight informed by the supplier can be different of the registered in the expedition.
- 9- The Waste Adm updates data in Disposal document and changes its status. People of invoice centralized reception receives automatically information to perform MIRO and MIGO, and also closes the purchase requisition.
- 10- The process is finished.

Dependencies with other applications

There is no dependencies of other applications, just the comun use of master data, like: material, specification.

Data loadings

Info providers and objects loaded

Process Chain name: PC_EHS_WASTE_FLOW

Process Chain Display Active Version: EHS Waste - daily

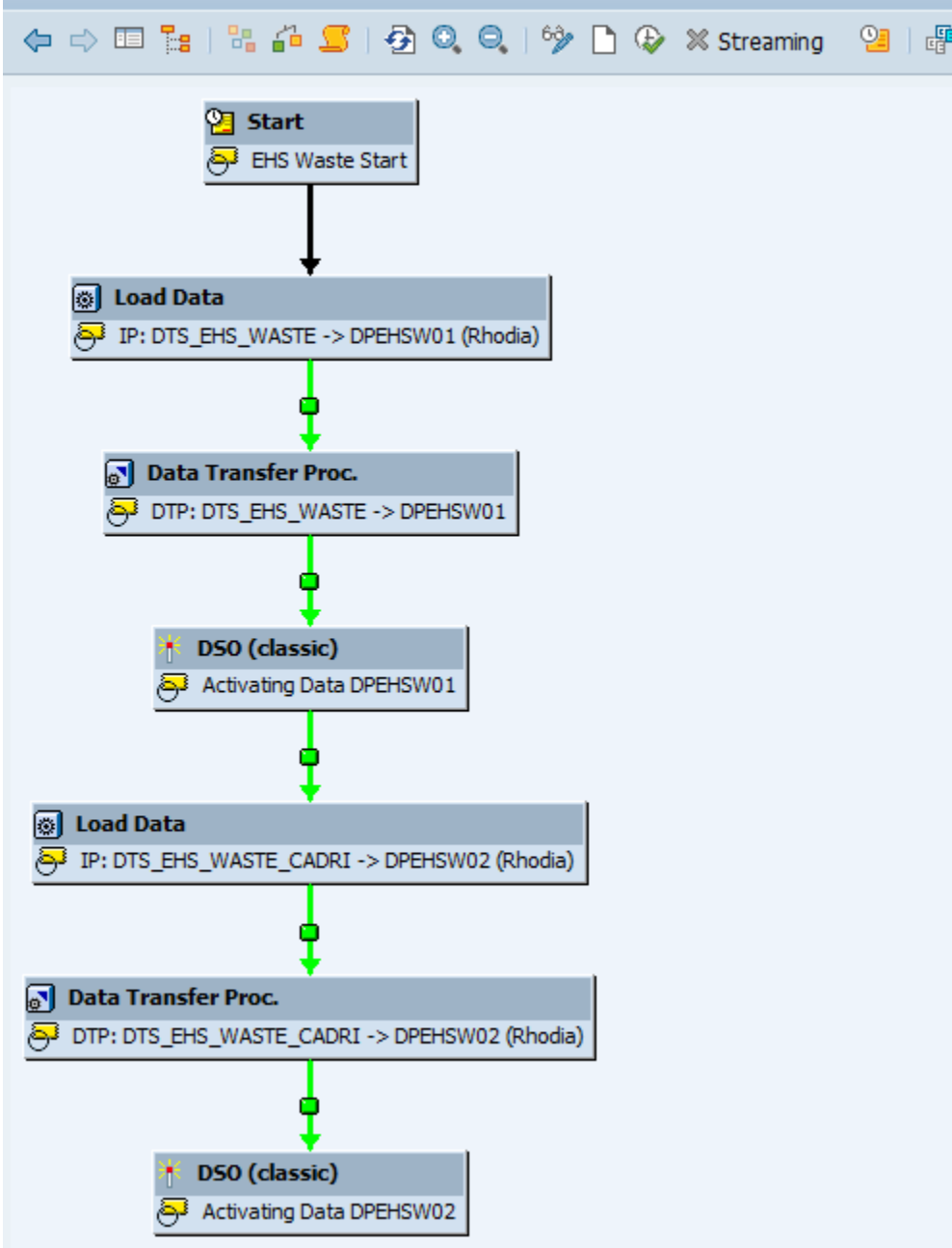

Remark: PC_EHS_WASTE was the original metachain, but has been replaced by chain PC_EHS_WASTE_FLOW, in order to be aligned with all BW systems

DataFlow:

Waste Management

Waste CADRI

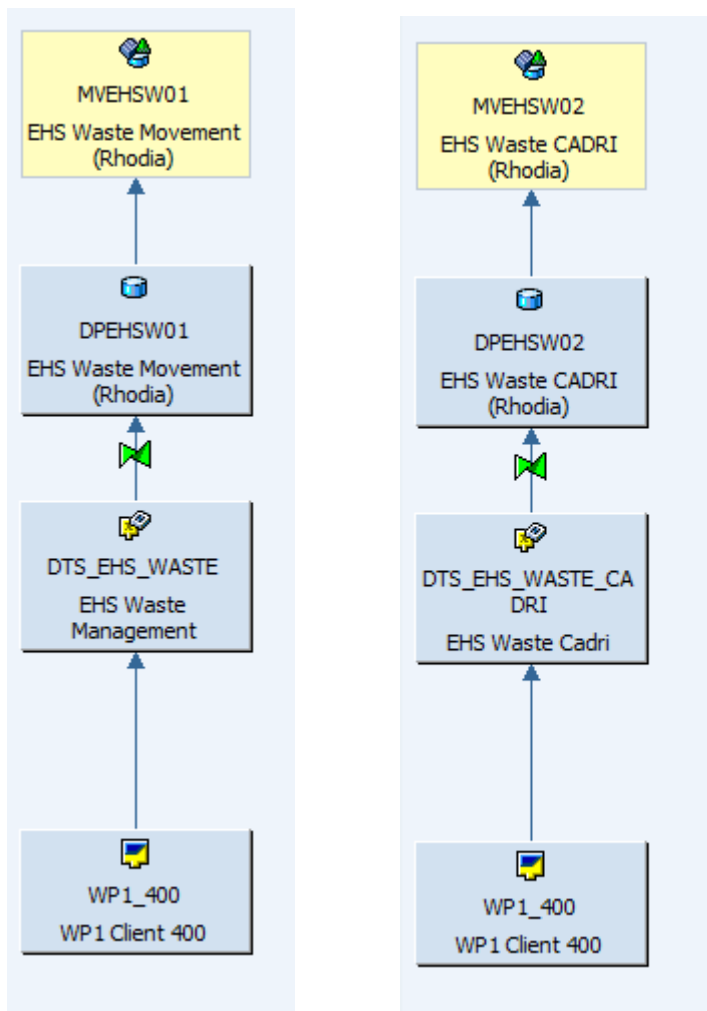

DSO DPEHSW01 - Waste movement

DataStore Object	Techn. name / val...	F...	O.	App...	Dat...	L	I
▼ EHS Waste Movement (Rhodia)	DPEHSW01						
▶ Object Information							
▶ Settings							
▼ Key fields							
• Source System	0LOGSYS				CHAR	10	
• Material	C_MATNR2				CHAR	18	
• Number of material document	C_MBLNR				CHAR	10	
• Follow-On Document	C_EASUCC				CHAR	32	
• Sort sequence of objects	C_ORD				NUMC	04	
▼ Data Fields							
• Specification	0EHS_SPEC				CHAR	12	
• Plant	C_PLANT				CHAR	04	
• Partner	C_PARTNER				CHAR	10	
• Purchase requisition number	C_BANFN				CHAR	10	
• Manifest Document	C_MANIFES				CHAR	60	
• Delivery number	C_DELNUM2				CHAR	10	
• Delivery Item (Core)	C_DELITM2				CHAR	16	
• Vendor number	C_VENDID				CHAR	10	
• Purchasing document category	C_BSTYP				CHAR	01	
• BW: Document Number	0DOC_NUM				CHAR	10	
• Purchase Order Item	C_PO_ITM				NUMC	06	
• Invoice Number	0INV_DOC_NO				CHAR	10	
• Purchasing Group	C_PUR_GRP				CHAR	03	
• RCS / Purchase Organisation	C_PUR_ORG				CHAR	04	
• Purchasing document type	C_BSART				CHAR	04	
• Long Description	C_TXTLG				CHAR	60	
• Sales document item category	C_ITMCAT				CHAR	04	
• Controlling area	0CO_AREA				CHAR	04	
• Cost Center	C_COSTCTR				CHAR	10	
• Object number	C_OBJNR				CHAR	22	
• Valid To	C_APVALTO				DATS	08	
• Waste Approval Number Assigned by Authority	C_APPNO				CHAR	20	
• Transport/Conversion: Identification (LIMU, TABU...)	C_IDENTIF				CHAR	08	
• Role-Dependent Partner Name	C_WADESCR				CHAR	50	
• Disposal Document Status	C_MNSTAT				CHAR	05	
• Document Category	C_EASUCAT				CHAR	06	
• Object Number	C_OBJNRB				CHAR	22	
• Vendor Emission date of invoice	C_EMISS				DATS	08	
• Created On	0ERDAT				DATS	08	
• Base Unit of Measure	0BASE_UOM				UNIT	03	
• Unit of measure	0UNIT				UNIT	03	
• Number of Containers (TR)	K_NUMCON				DEC	09	
• Quantity	K_EAINTAM				QUAN	09	
• Outgoing quantity	K_EAEXTAM				QUAN	09	
• Invoiced quantity	0INVCD_QTY				QUAN	09	
• GL - Shipment Date	C_DTEMB				DATS	08	

▼ EHS Waste CADRI (Rhodia)	DPEHSW02		
▶ Object Information			
▶ Settings			
▼ Key fields			
• Source System	0LOGSYS	CHAR	10
• Material	C_MATNR2	CHAR	18
• Vendor number	C_VENDID	CHAR	10
• Waste Approval Number Assigned by Authority	C_APPNO	CHAR	20
• Waste Generation, Waste Disposal, or Waste Tran	C_BPWANO	CHAR	10
• Waste Code	C_WASTE	CHAR	30
• Valid From	C_APVALFR	DATS	08
• Valid To	C_APVALTO	DATS	08
▼ Data Fields			
• BW: Document Number	ODOC_NUM	CHAR	10
• Purchase Order Item	C_PO_ITM	NUMC	06
• Plant	C_PLANT	CHAR	04
• Created On	0ERDAT	DATS	08
• Unit of measure	0UNIT	UNIT	03
• Qty Disposed of for Period	K_QTDISPO	QUAN	09
• Licensed Quantity for Period	K_QTLICEN	QUAN	09

Datasources:

DTS_EHS_WASTE - EHS Waste Movement

Generic Delta	
DataSource	DTS_EHS_WASTE
Applic. Component	EHS-IO
Data Reconciliation	<input type="checkbox"/>
Obj. status	Saved
Texts	
Short description	EHS Waste Management
Medium description	EHS Waste Management
Long description	EHS Waste Management
Extraction from DB View	
View/Table	
ExtractStruct.	
Extraction frm SAP Query	
InfoSet	
Extraction by Function Module	
Function Module	Z_WBW_DTS_EHS_WASTE
Extract.Struct.	ZWBWS028

Based on Function Module Z_WBW_DTS_EHS_WASTE

This function module is an left outer join selection of tables below:

```

SELECT ehswat_entam~matnr " Waste Material
ehswat000~partner " Waste management business partner */
ehswat_entam~crdat " Created On */
ehswat_entam~entamno " Entry document for Disposal Processing */
ehswat_entam~anzgeb " Number of Containers */
ehswat_entam~eaintam " Quantity */
ehswat_entam~eaextam " Outgoing quantity */
ehswat_entam~objnr " Object number
ehswat_entam~reclbpgen
ehswat_entam~recln
ehswat_entam~reclroot
ehswat_enacc~kokrs " CO AREA
ehswat_enacc~kostl " Cost Center */
ehswat_bpdefinit~objnum " Master Data Object Key */
ehswat_enfod~easucc " Follow-On Document */
ehswat_enfod~easucccat " Follow-On Document */
ehswat_enprt~eabpcount " Counter

```

```

ehswat_enfod~easucc AS banfn
ehswat_entam~matnr AS wrkst
ehswat_entam~matnr AS subid
ehswat_entam~matnr AS ident
ehswat_entam~anzgebeinh
ehswat_entam~eaintamu " Unit
ehswat_entam~eaextamu " Unit

```

```

FROM ehswat_entam " Disposal Processing (Quantity Entry/Planning)
LEFT OUTER JOIN ehswat_enprt " Disposal Processing: Partner for Entry Document
ON ehswat_enprt~recnroot = ehswat_entam~recn
AND ehswat_enprt~delflg = ''
LEFT OUTER JOIN ehswat_enacc " Disposal Processing: Account Assignments for Entry
ON ehswat_enacc~recnroot = ehswat_entam~recn
AND ehswat_enacc~delflg = ''
LEFT OUTER JOIN ehswat_enfod " Disposal Processing: Follow-On Document Table
ON ehswat_enfod~eapred = ehswat_entam~entamno " Entry Document
AND ehswat_enfod~easucccat EQ 'SAP009' " Document Category
AND ehswat_enfod~delflg = ''
LEFT OUTER JOIN ehswat001
ON ehswat001~recn = ehswat_entam~recnbpge
AND ehswat001~delflg = ''
INNER JOIN ehswat100
ON ehswat100~recn = ehswat001~recn
* ON ehswat100~recn = ehswat_entam~recnbpge
AND ehswat100~delflg = ''
INNER JOIN ehswat000 " Master Table for the Waste Management
ON ehswat000~recn = ehswat100~recnroot

LEFT OUTER JOIN ehswat_bpdefinit " MD: Partner Reference to Master Data Objects

ON ehswat_bpdefinit~recnroot = ehswat100~recn
AND ehswat_bpdefinit~delflg = ''

```

And individual selections in tables below:

```

SELECT jest~objnr
tj30t~txt30
INTO TABLE t_jest
FROM jest " Individual Object Status */
INNER JOIN tj30t " Texts for User Status */
ON tj30t~estat = jest~stat
FOR ALL ENTRIES IN t_collect_objnr
WHERE jest~objnr = t_collect_objnr~objnr
AND jest~inact NE 'X'
AND tj30t~spras = 'P'
AND tj30t~stsma = 'ZEHS_WMM' .

```

```

SELECT matnr
wrkst
INTO TABLE t_mara
FROM mara
FOR ALL ENTRIES IN t_collect_matnr
WHERE matnr = t_collect_matnr~matnr.

```

```

SELECT estrh~subid
estri~ident
INTO CORRESPONDING FIELDS OF TABLE t_estrh
FROM estrh
INNER JOIN estri
ON estrh~recn = estri~recnroot
FOR ALL ENTRIES IN t_collect_subid
WHERE estrh~subid = t_collect_subid~subid
AND estri~delflg NE 'X'
AND estrh~delflg NE 'X'.

```

```

SELECT recn recnroot wadescrpfog
INTO TABLE t_ehswat001_descr
FROM ehswat001_descr
FOR ALL ENTRIES IN t_data_aux
WHERE recnroot = t_data_aux~recnbpge
AND langu = 'P'.

```

```

SELECT mnino
mnstatus
zso_delivery
zso_item
zso_order
zso_item
zs_emission
zs_quantity
zs_uom
zsinv_number
zs_manifest_doc
zs_vend_inv_doc
ehswat_approval~appno
ehswat_approval~apvalto
INTO TABLE t_ehswat_mn
FROM ehswat_mn
LEFT OUTER JOIN ehswat_approval " MD: Waste Approval
ON ehswat_approval~recn = ehswat_mn~mnappno
AND ehswat_approval~delflg = ' '
FOR ALL ENTRIES IN t_ehswat_enfod
WHERE mnino = t_ehswat_enfod~mnino
AND ehswat_mn~delflg NE 'X'.

```

```

SELECT lips~vbeln
lips~posnr
lips~werks " Plant */
lips~pstyv " Sales document item category
lips~erdat
INTO TABLE t_lips
FROM lips
FOR ALL ENTRIES IN t_collect_delivery
WHERE vbeln = t_collect_delivery~delivery.

```

```

SELECT eban~ekorg " Plant */
eban~ekgrp " Sales document item category
eban~banfn
eban~bsart
eban~bstyp
eban~ebeln
eban~ebelp
eban~flief
eban~werks
INTO TABLE t_eban
FROM eban
FOR ALL ENTRIES IN t_ehswat_enfod
WHERE banfn = t_ehswat_enfod~banfn.

```

DTS_EHS_WASTE_CADRI - EHS Waste Movement

This datasource is based on view ZBWEHS_WAS_CADRI

DataSource	DTS_EHS_WASTE_CADRI
Applic. Component	EHS-IO
Data Reconciliation	<input type="checkbox"/>
Obj. status	Saved
Texts	
Short description	EHS Waste CADRI
Medium description	EHS Waste Cadri
Long description	EHS Waste Cadri
Extraction from DB View	
View/Table	ZBWEHS_WAS_CADRI <input type="checkbox"/>
ExtractStruct.	ZOXWD10635
Extraction frm SAP Query	
InfoSet	
Extraction by Function Module	
Function Module	
Extract.Struct.	

View: ZBWEHS_WAS_CADRI - EHS Waste Cadri

Database view ZBWEHS_WAS_CADRI Active

Short Description EHS Waste Cadri

Attributes

Table/Join Conditions

View Flds

Selection Conditions

Maint.Status



Tables

EHSWAT002
EHSWAT_BPDEFINIT
EHSWAT_APPROVAL
EHSWAT_APPAMOUNT
EHSWAT001_DESCR
EHSWAT003
EHSWAT_DCAPP
EHSWAT_APPWAKEY
EHSWAT001

Join conditions

Table	Field name	=	Table	Field name
EHSWAT_APPWAKEY	MANDT	=	EHSWAT_DCAPP	MANDT
EHSWAT_APPROVAL	MANDT	=	EHSWAT_APPWAKEY	MANDT
EHSWAT003	MANDT	=	EHSWAT002	MANDT
EHSWAT002	MANDT	=	EHSWAT_BPDEFINIT	MANDT
EHSWAT001_DESCR	MANDT	=	EHSWAT_APPROVAL	MANDT
EHSWAT_DCAPP	MANDT	=	EHSWAT001_DESCR	MANDT
EHSWAT_APPAMOUNT	MANDT	=	EHSWAT_DCAPP	MANDT
EHSWAT001	MANDT	=	EHSWAT_APPAMOUNT	MANDT
EHSWAT_BPDEFINIT	RECNR001	=	EHSWAT001	RECNR
EHSWAT001_DESCR	RECNR001	=	EHSWAT001	RECNR
EHSWAT002	RECNR001	=	EHSWAT001	RECNR
EHSWAT_APPAMOUNT	RECNR001	=	EHSWAT_APPWAKEY	RECNR
EHSWAT_APPWAKEY	RECNR001	=	EHSWAT_APPROVAL	RECNR
EHSWAT003	RECNR	=	EHSWAT_DCAPP	RECNRDISCH
EHSWAT_DCAPP	RECNRAPP	=	EHSWAT_APPROVAL	RECNR
EHSWAT003	RECNRMASTD	=	EHSWAT002	RECNR

View field	Table	Field	Key	Data elem.	M...	DTyp	Length	Short description
MAINR	EHSWAT002	MATNR	<input checked="" type="checkbox"/>	EHSWAE_WASTE	<input type="checkbox"/>	CHAR	18	Material That Represents the Waste
OBJNUM	EHSWAT_BPDEFINII	OBJNUM	<input checked="" type="checkbox"/>	EHSWAE_OBJNUM	<input type="checkbox"/>	CHAR	100	Master Data Object Key
WADESCRPOFG	EHSWAT001_DESCR	WADESCRPOFG	<input checked="" type="checkbox"/>	EHSWAE_DESCRPOFG	<input type="checkbox"/>	CHAR	50	Role-Dependent Partner Name
APPNO	EHSWAT_APPROVAL	APPNO	<input checked="" type="checkbox"/>	EHSWAE_APPNO	<input type="checkbox"/>	CHAR	20	Waste Approval Number Assigned by Authority
APAMVALFR	EHSWAT_APPAMOUNT	APAMVALFR	<input checked="" type="checkbox"/>	EHSWAE_APAMVALFR	<input type="checkbox"/>	DATS	8	Valid From
APAMVALTO	EHSWAT_APPAMOUNT	APAMVALTO	<input checked="" type="checkbox"/>	EHSWAE_APAMVALTO	<input type="checkbox"/>	DATS	8	Valid To
APPERQUAN	EHSWAT_APPAMOUNT	APPERQUAN	<input checked="" type="checkbox"/>	EHSWAE_APPERQUAN	<input type="checkbox"/>	QUAN	13	Licensed Quantity for Period
APPERDISQUAN	EHSWAT_APPAMOUNT	APPERDISQUAN	<input checked="" type="checkbox"/>	EHSWAE_APPERDISQUAN	<input type="checkbox"/>	QUAN	13	Quantity Disposed of for Period
BPWANO	EHSWAT002	BPWANO	<input checked="" type="checkbox"/>	EHSWAE_BPWANO	<input type="checkbox"/>	CHAR	10	Waste Generation, Waste Disposal, or Waste Transport
CRDAT	EHSWAT_APPAMOUNT	CRDAT	<input checked="" type="checkbox"/>	ESECRDAT	<input type="checkbox"/>	DATS	8	Created On
EBELN	EHSWAT003	EBELN	<input checked="" type="checkbox"/>	EHSWAE_EBELN	<input type="checkbox"/>	CHAR	10	Purchasing Document
EBLEP	EHSWAT003	EBLEP	<input checked="" type="checkbox"/>	EBLEP	<input type="checkbox"/>	NUMC	5	Item Number of Purchasing Document
UPDDAT	EHSWAT_APPAMOUNT	UPDDAT	<input checked="" type="checkbox"/>	ESEUPDDAT	<input type="checkbox"/>	DATS	8	Changed On
APWAKEY	EHSWAT_APPWAKEY	APWAKEY	<input checked="" type="checkbox"/>	EHSWAE_WAKEYIDE_SHORT	<input type="checkbox"/>	CHAR	30	Waste Code
APPERU	EHSWAT_APPAMOUNT	APPERU	<input checked="" type="checkbox"/>	EHSWAE_PERU	<input type="checkbox"/>	UNIT	3	Unit of Measure for Licensed Quantity
APPERCKU	EHSWAT_APPAMOUNT	APPERCKU	<input checked="" type="checkbox"/>	EHSWAE_APCKU	<input type="checkbox"/>	UNIT	3	Unit of Measure for Alert Quantity
APPERDISU	EHSWAT_APPAMOUNT	APPERDISU	<input checked="" type="checkbox"/>	EHSWAE_DISU	<input type="checkbox"/>	UNIT	3	Unit of Measure for Quantity Disposed Of
CRNAM	EHSWAT_APPAMOUNT	CRNAM	<input checked="" type="checkbox"/>	ESECRNAM	<input type="checkbox"/>	CHAR	12	Created By
APPQUAN	EHSWAT_APPWAKEY	APPQUAN	<input checked="" type="checkbox"/>	EHSWAE_APPQUAN	<input type="checkbox"/>	QUAN	13	Total Licensed Quantity for the Approval and Waste Code
APDISQUAN	EHSWAT_APPWAKEY	APDISQUAN	<input checked="" type="checkbox"/>	EHSWAE_APDISQUAN	<input type="checkbox"/>	QUAN	13	Quantity Disposed Of
APCKQUAN	EHSWAT_APPWAKEY	APCKQUAN	<input checked="" type="checkbox"/>	EHSWAE_APCKQUAN	<input type="checkbox"/>	QUAN	13	Alert Quantity
APCKU	EHSWAT_APPWAKEY	APCKU	<input checked="" type="checkbox"/>	EHSWAE_APCKU	<input type="checkbox"/>	UNIT	3	Unit of Measure for Alert Quantity
APDISU	EHSWAT_APPWAKEY	APDISU	<input checked="" type="checkbox"/>	EHSWAE_DISU	<input type="checkbox"/>	UNIT	3	Unit of Measure for Quantity Disposed Of
APPQUANU	EHSWAT_APPWAKEY	APPQUANU	<input checked="" type="checkbox"/>	EHSWAE_PERU	<input type="checkbox"/>	UNIT	3	Unit of Measure for Licensed Quantity
APDISMETH	EHSWAT_APPWAKEY	APDISMETH	<input checked="" type="checkbox"/>	EHSWAE_APDISMETH	<input type="checkbox"/>	CHAR	21	Disposal Method
APDISCAT	EHSWAT_APPWAKEY	APDISCAT	<input checked="" type="checkbox"/>	EHSWAE_APDISCAT	<input type="checkbox"/>	CHAR	21	Type of disposal

Table	Field name	Operator	Comparison Value	AND/...
EHSWAT_BPDEFINII	OBJART	EQ	'VENDOR'	AND
EHSWAT001_DESCR	LANGU	EQ	'P'	AND
EHSWAT_APPAMOUNT	DELFLG	NE	'X'	AND
EHSWAT_APPWAKEY	DELFLG	NE	'X'	AND
EHSWAT_APPWAKEY	DELFLG	NE	'X'	

Loading frequency

Daily full.

Average performance

This is a daily load running in 1 minute with 2000 records loaded.

Key Figure	Estimation
~ Average Process Chain Runtime	1 min
~ Average nb of rows loaded per load	2000
~ Total nb of rows loaded (if full)	2000
~ Average Runtime for 10k lines	1 min

Record Keeping

Around 2000 records per year per plant.

Reporting

Queries End User Documentation

Main queries

BW_QRY_MVEHSW01_0001 - EHS Waste Movement (core query)

This query is used to analyze the data stored in WASTE movement

Filters

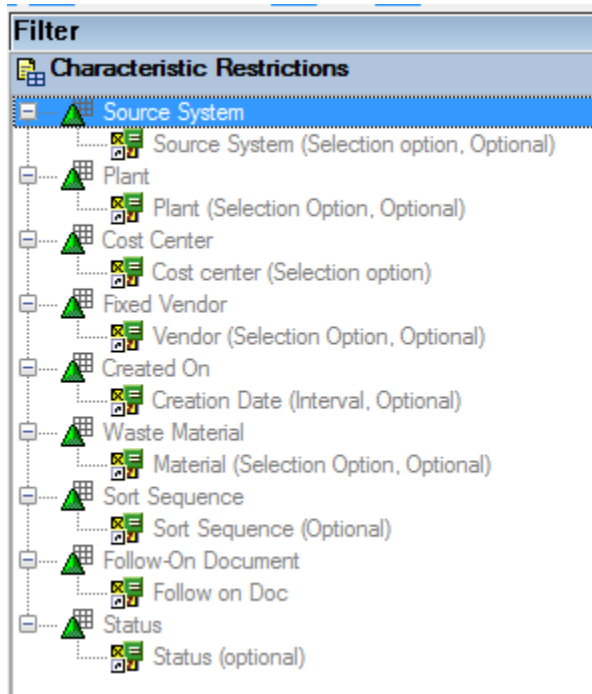

Rows

- Rows**
- Source System
 - Waste Material
 - Partner
 - Role-Dependent Partn
 - Created On
 - Shipment Date
 - Entry document
 - Status
 - Purchase Order
 - Fixed Vendor
 - Controlling area
 - Cost Center
 - Master data obj. key
 - Follow-On Document
 - Disposal Document Status
 - Delivery number
 - Authority-assigned waste approval no
 - Valid To
 - Vendor Invoice
 - Emission date of invoice
 - Identifier

Columns

- Columns**
- Key Figures
 - Number of Containers
 - Entry Quantity
 - Outgoing quantity
 - Quantity - Vendor Invoice
 - Stock adjustment

Navigational Attributes

- Free Characteristics**
- Company code
 - Country of Plant
 - Geography / Zone
 - Identification Type
 - Identification Categ
 - Purchase requisition number
 - Purchasing doc type
 - RCS / Purchase Organisation
 - Purchasing Group
 - Delivery Item
 - BFC Global Business Unit
 - Authorization Group
 - Division
 - Material group
 - Material type
 - Sort Sequence

Lay-Out

Waste Material	Partner	Role-Dependent Partn	Created On	Shipment Date	Entry document	Status	Purchase Order	Fixed Vendor		
2024968	ACIDO SALICILICO FORA ESPECIFICA	1000000020	#	01/12/2015	16/12/2015	800000011	Confirmado	#	WP1_400/Not assigned	
2024968	ACIDO SALICILICO FORA ESPECIFICA	1000000020	#	02/02/2016	19/09/2016	800000139	Confirmado	#	WP1_400/Not assigned	
2024968	ACIDO SALICILICO FORA ESPECIFICA	1000000020	#	20/04/2016	19/09/2016	800000311	Confirmado	#	WP1_400/Not assigned	
2024968	ACIDO SALICILICO FORA ESPECIFICA	1000000020	#	29/06/2016	19/09/2016	800000491	#	#	WP1_400/Not assigned	
2024968	ACIDO SALICILICO FORA ESPECIFICA	1000000020	#	01/08/2016	19/09/2016	800000554	Confirmado	4502841791	124482	REVALORE COPROCESSAMENTO I
2024971	AREA DE PROCESSO - GR	1000000035	BR PAULNIA-SILICAS-Geral	17/12/2015	18/12/2015	800000100	#	#	#	WP1_400/Not assigned
2024971	AREA DE PROCESSO - GR	1000000035	BR PAULNIA-SILICAS-Geral	17/12/2015	18/12/2015	800000101	#	#	#	WP1_400/Not assigned
2024971	AREA DE PROCESSO - GR	1000000035	BR PAULNIA-SILICAS-Geral	18/12/2015	28/12/2015	800000083	Confirmado	#	#	WP1_400/Not assigned
2024971	AREA DE PROCESSO - GR	1000000035	BR PAULNIA-SILICAS-Geral	18/12/2015	28/12/2015	800000084	#	#	#	WP1_400/Not assigned
2024971	AREA DE PROCESSO - GR	1000000035	BR PAULNIA-SILICAS-Geral	18/12/2015	18/05/2016	800000106	Confirmado	#	#	WP1_400/Not assigned
2024971	AREA DE PROCESSO - GR	1000000035	BR PAULNIA-SILICAS-Geral	18/12/2015	29/08/2016	800000105	#	#	#	WP1_400/Not assigned
2024971	AREA DE PROCESSO - GR	1000000035	BR PAULNIA-SILICAS-Geral	04/03/2016	11/03/2016	800000200	#	#	#	WP1_400/Not assigned
2024971	AREA DE PROCESSO - GR	1000000035	BR PAULNIA-SILICAS-Geral	04/03/2016	11/03/2016	800000201	Confirmado	#	#	WP1_400/Not assigned
2024971	AREA DE PROCESSO - GR	1000000035	BR PAULNIA-SILICAS-Geral	23/03/2016	20/04/2016	800000222	Confirmado	#	#	WP1_400/Not assigned
2024971	AREA DE PROCESSO - GR	1000000035	BR PAULNIA-SILICAS-Geral	29/08/2016	29/08/2016	800000658	Confirmado	#	#	WP1_400/Not assigned
2024971	AREA DE PROCESSO - GR	1000000035	BR PAULNIA-SILICAS-Geral	05/09/2016	09/09/2016	800000665	#	#	#	WP1_400/Not assigned
2024974	RESIDUOS DE BISFENOL - TB	1000000010	#	01/12/2015	16/12/2015	800000008	Confirmado	4502646293	124482	REVALORE COPROCESSAMENTO I

Delivery number	Authority-assigned waste approval no	Valid To	Vendor Invoice	Emission date of invoice	Identifier	Number of Containers	Entry Quantity	Outgoing quantity	Quantity - Vendor Invoice	Stock adjustment
190028360	00000000000037002385	28/01/2016	6191	20/01/2016	BRWC	40	17.600,0 KG	9.840,0 KG	9.840,0 KG	7.760,0 KG
190031221	00000000000037002466	16/04/2017	#	#	BRWC	8	3.520,0 KG	2.038,7 KG	0,0	1.481,3 KG
190031221	00000000000037002466	16/04/2017	#	#	BRWC	11	4.840,0 KG	2.803,2 KG	0,0	2.036,8 KG
190031221	00000000000037002466	16/04/2017	#	#	BRWC	4	1.760,0 KG	1.019,4 KG	0,0	740,6 KG
190031221	00000000000037002466	16/04/2017	#	#	BRWC	8	3.520,0 KG	2.038,7 KG	0,0	1.481,3 KG
190028379	00000000000037002386	20/08/2017	6195	20/01/2016	BRWC	1	54.000,0 KG	42.000,0 KG	42.440,0 KG	12.000,0 KG
190028380	00000000000037002386	20/08/2017	6194	20/01/2016	BRWC	1	54.000,0 KG	43.120,0 KG	43.000,0 KG	10.880,0 KG
190028420	00000000000037002386	20/08/2017	132	01/03/2016	BRWC	1	54.000,0 KG	43.120,0 KG	44.100,0 KG	10.880,0 KG
190028421	00000000000037002189	14/10/2016	132	01/03/2016	BRWC	1	54.000,0 KG	44.200,0 KG	44.100,0 KG	9.800,0 KG
190029851	00000000000037002386	20/08/2017	6933	30/06/2016	BRWC	1	54.000,0 KG	51.080,0 KG	48.720,0 KG	2.920,0 KG
190031003	00000000000037002386	20/08/2017	7402	30/09/2016	BRWC	1	54.000,0 KG	39.300,0 KG	41.360,0 KG	14.700,0 KG
190029154	00000000000037002386	20/08/2017	6496	31/03/2016	BRWC	1	54.000,0 KG	51.320,0 KG	51.240,0 KG	2.680,0 KG
190029155	00000000000037002386	20/08/2017	6495	31/03/2016	BRWC	1	54.000,0 KG	43.160,0 KG	43.200,0 KG	10.840,0 KG
190029566	00000000000037002386	20/08/2017	6740	31/05/2016	BRWC	1	54.000,0 KG	45.900,0 KG	45.880,0 KG	8.100,0 KG
190031002	00000000000037002386	20/08/2017	7401	30/09/2016	BRWC	1	54.000,0 KG	41.360,0 KG	39.400,0 KG	12.640,0 KG
190031122	00000000000037002386	20/08/2017	7403	30/09/2016	BRWC	1	54.000,0 KG	43.820,0 KG	43.600,0 KG	10.180,0 KG
190028361	00000000000037002385	12/04/2016	6299	19/02/2016	160305	48	21.120,0 KG	16.480,0 KG	16.240,0 KG	4.640,0 KG
190030599	00000000000037002525	28/01/2018	7258	31/08/2016	160305	40	17.600,0 KG	10.764,7 KG	18.020,0 KG	6.835,3 KG

BW_QRY_MVEHSW02_0001 - EHS Waste CADRI (core query)

This query is used to analyze the data stored in CADRI repository

Filters

Filter

Characteristic Restrictions

- Source System
- Source System (Selection option, Optional)
- Created On
- Creation Date (Interval, Optional)
- Waste Material
- Material (Selection Option, Optional)
- Vendor number
- Vendor (Selection Option, Optional)

Rows

Rows

- Source System
- Waste Material
- Vendor number
- Authority-assigned waste approval no.
- Valid From
- Valid To

Columns

Columns

- Key Figures
 - Licensed Quantity
 - Qty Disposed
 - Difference

Navigational Attributes

Free Characteristics

- Waste Generation
- Waste Code
- Created On
- PO Number
- Purchase Order Item
- Plant
- Material group
- Material type

Lay-Out

Source System	Waste Material	Vendor number	Authority-assigned waste approval no.	Valid From	Valid To	Licensed Quantity	Qty Disposed	Difference	
WP1_400	2024968	124482	REVALORE COPROCESSAM	10/08/2015	28/01/2016	81.360 KG	4.920 KG	76.440 KG	
WP1_400	2024968	124482	REVALORE COPROCESSAM	07/12/2015	31/12/2015	80.000 KG	0 KG	80.000 KG	
WP1_400	2024968	124482	REVALORE COPROCESSAM	01/01/2016	31/12/2016	80.000 KG	3.950 KG	76.050 KG	
WP1_400	2024968	124482	REVALORE COPROCESSAM	01/01/2017	16/04/2017	80.000 KG	0 KG	80.000 KG	
WP1_400	2024969	90708	HOLCIM BRASIL S A	28/05/2014	31/12/2014	30.000 KG	0 KG	30.000 KG	
WP1_400	2024969	90708	HOLCIM BRASIL S A	01/01/2015	31/12/2015	30.000 KG	0 KG	30.000 KG	
WP1_400	2024969	90708	HOLCIM BRASIL S A	01/01/2016	28/05/2016	30.000 KG	0 KG	30.000 KG	
WP1_400	2024970	90708	HOLCIM BRASIL S A	28/05/2014	31/12/2014	30.000 KG	0 KG	30.000 KG	
WP1_400	2024970	90708	HOLCIM BRASIL S A	01/01/2015	31/12/2015	30.000 KG	0 KG	30.000 KG	
WP1_400	2024970	90708	HOLCIM BRASIL S A	01/01/2016	28/05/2016	30.000 KG	0 KG	30.000 KG	
WP1_400	2024971	90708	HOLCIM BRASIL S A	28/05/2014	31/12/2014	1.800.000 KG	0 KG	1.800.000 KG	
WP1_400	2024971	90708	HOLCIM BRASIL S A	01/01/2015	31/12/2015	1.800.000 KG	0 KG	1.800.000 KG	
WP1_400	2024971	90708	HOLCIM BRASIL S A	01/01/2016	28/05/2016	1.800.000 KG	0 KG	1.800.000 KG	
WP1_400	2024971	124482	REVALORE COPROCESSAM	20/08/2015	31/12/2015	1.889.930 KG	64.610 KG	1.825.320 KG	
WP1_400	2024971	124482	REVALORE COPROCESSAM	01/01/2016	31/12/2016	2.000.000 KG	157.970 KG	1.842.030 KG	
WP1_400	2024971	124482	REVALORE COPROCESSAM	01/01/2017	20/08/2017	2.000.000 KG	0 KG	2.000.000 KG	
WP1_400	2024971	2500041184	CRH CANTAGALO INDUSTRIA	00000000000037002189	22/11/2014	14/10/2016	1.200.000 KG	22.050 KG	1.177.950 KG
WP1_400	2024974	90708	HOLCIM BRASIL S A	00000000000037002011	28/05/2014	31/12/2014	220.000 KG	0 KG	220.000 KG
WP1_400	2024974	90708	HOLCIM BRASIL S A	00000000000037002011	01/01/2015	31/12/2015	220.000 KG	0 KG	220.000 KG
WP1_400	2024974	90708	HOLCIM BRASIL S A	00000000000037002011	01/01/2016	28/05/2016	220.000 KG	19.870 KG	200.130 KG
WP1_400	2024974	124482	REVALORE COPROCESSAM	00000000000037002385	10/08/2015	28/12/2015	743.650 KG	8.240 KG	735.410 KG
WP1_400	2024974	124482	REVALORE COPROCESSAM	00000000000037002525	14/03/2016	31/12/2016	400.000 KG	29.050 KG	370.950 KG
WP1_400	2024974	124482	REVALORE COPROCESSAM	00000000000037002525	01/01/2017	31/12/2017	400.000 KG	0 KG	400.000 KG

Main functionalities

Broadcast

No broadcast defined for this.

Maintenance

Known bugs

Not detected yet.

Recurring procedure

Planned Evolution

The solution must be spread for other plants and countries in the future.