

# BW OTC - SPM /\ Obsolete /\



The new wiki link for this data flow is here:

[Technical Documentation - Sustainable portfolio management \(SPM\)](#)

Please update the doc there and no longer here.



- General presentation
  - Objective of the application
  - List of contacts
  - Usage information
  - History
- Roles & Access
  - Roles and access
  - Authorization objects
- Dataflow overview
  - Functional and Technical rules on Workbench + Reporting
  - Rules & Explanations
    - Acquisition of data
    - Transformation of data (Derivation of SPM characteristics)
      - 1) Derive SPM product
      - 2) Derive SPM PAC (Application)
      - 3) Recalculate SPM product
    - List of SPM mapping tables
    - Special case 1 - GBU Specialty Polymers
    - Special case 2 - Composite Materials
    - Master Data from PF7
  - Dependencies with other applications
- Data loadings
  - Info providers and objects loaded
  - Loading frequency
  - Average performance
  - Record Keeping
- Reporting
  - Queries End User Documentation
  - Main queries
  - Main functionalities
  - Broadcast
- Maintenance
  - Known bugs
  - Recurring procedure
  - Planned Evolution

## General presentation

### Objective of the application

SPM stands for "**Sustainability Portfolio Management**". It's a Solvay proprietary approach to assess business sustainability risks and opportunities that runs on PF7.

The objective of **SPM reporting in BW** is to provide a "Sustainability view" (Market Alignment, Operations Vulnerability) for the sales of the group.

Sales are extracted from P&L in WBP and then enhanced with an SPM dimension, through a sequence of steps (lookup in mapping tables).

SPM Master Data (SPM Product, SPM Application) is loaded from PF7.

Final report is in QlikView dashboards.

### List of contacts

- Functional Owner: **Jean-Francois Goupillier** (previously **Marc Piret**)
- IS Reporting Leader: Diogo Paiva (IS Supply Chain M&S Data)
- BW Developer: Laressa Moretti (SBS IS)

## Usage information

## History

2017 - First development covering most of the GBUs (pilot: Aroma and Special Chem)

link to the project folder: <https://drive.google.com/drive/folders/0BxkySrtHryoBejV1VG5CbmNwM3c>

2018 - Extension for GBU Specialty Polymers and Composite Materials

link to the project folder: <https://drive.google.com/drive/folders/18bJbaF-EfKSDfYI5X1uWe25xiwa99CIU>

### June/2021 - Project SPM Improvements (will be detailed hereafter)

User documentation:

<https://docs.google.com/presentation/d/1CwoaT-wgde7CVazHWES1HsKtRuyxxK8w95ir1SG3zFo>

## Roles & Access

### Roles and access

List of application role + menu role and explanation if we have several applications role with specials rules.

Role Code	Role Description	Explanation
ZBI_RCS_SPM_A01	Sustainable Portfolio Management - End User Role	Role for the application
ZR_RCS_CA_M58	SPM - Sustainable Portfolio Management	Role menu for the application

### Authorization objects

List of authorization objects mandatory for the application.

Authorization object	Explanation
CPFCTR1_2	GBU

## Dataflow overview

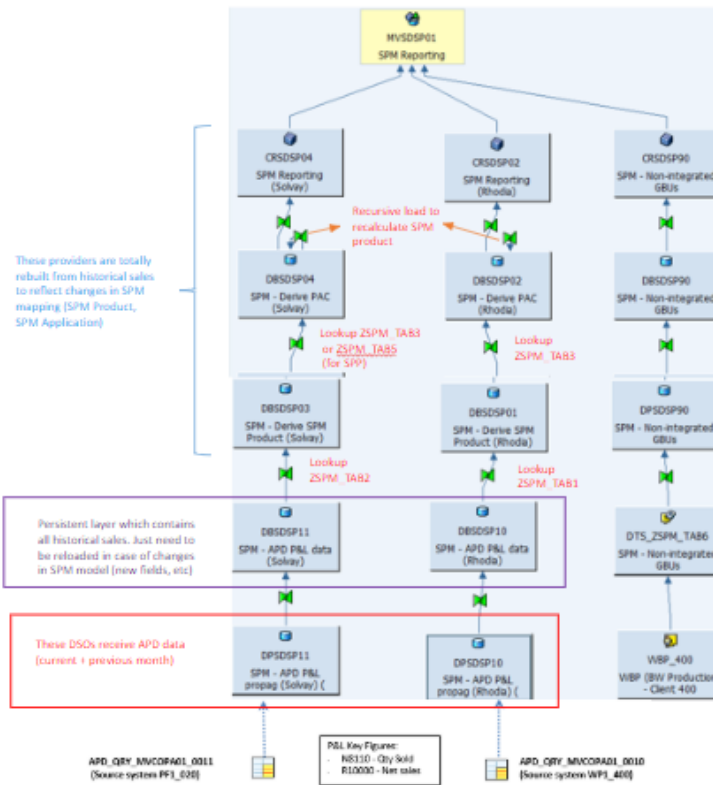

The InfoArea where SPM is located is IA\_SD\_SPM.

There is one MultiProvider named MVSDSP01.

<ul style="list-style-type: none"> <li>▼  SPM - Sustainable Portfolio Management</li> <li>▶  SPM - Master Data Layer</li> <li>▶  SPM - Propagation Layer</li> <li>▶  SPM - Business Transformation Layer</li> <li>▶  SPM - Reporting Layer</li> <li>▼  SPM - Virtual Layer</li> <li>▼  SPM Reporting</li> <li>▶  SPM - Non-integrated GBUs</li> <li>▶  SPM Reporting (Rhodia)</li> <li>▶  SPM Reporting (Solvay)</li> </ul>	<ul style="list-style-type: none"> <li>IA_SD_SPM</li> <li>IA_SD_SPM_MD</li> <li>IA_SD_SPM_PROP</li> <li>IA_SD_SPM_BUSINESS</li> <li>IA_SD_SPM_REPORTING</li> <li>IA_SD_SPM_VIRTUAL</li> <li>MVSDSP01</li> <li>CRSDSP90</li> <li>CRSDSP02</li> <li>CRSDSP04</li> </ul>
---	---

## Functional and Technical rules on Workbench + Reporting Rules & Explanations

### Acquisition of data

Sales data is loaded from P&L using APDs.

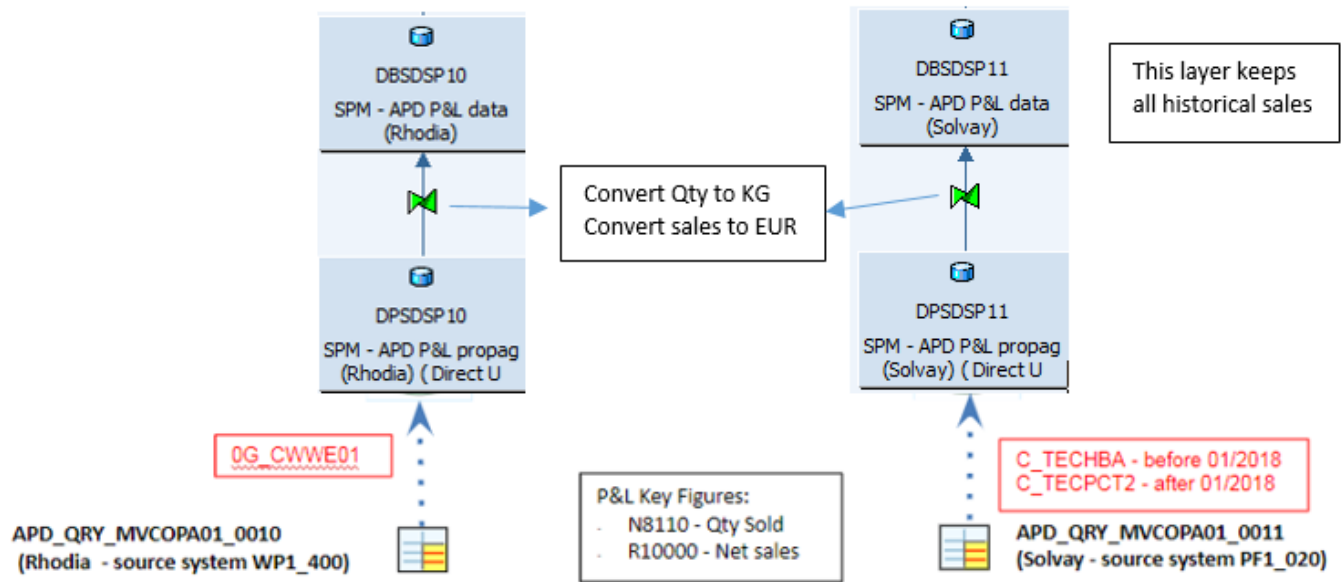

The APDs load current + previous month into Direct Update DSOs, then it goes to the next level DSOs, which keep all historical sales (allowing a complete recalculation of SPM data every day).

The Sub-Activity field (0G\_CWWE01) is very important to define the GBU and Group of Activities.

From Rhodia query, it gets directly field C\_TECMAT-0G\_CWWE01 (normally IECRAxxx)

From Solvay query, (due to PQ1 decommission and SpS projects), it gets from different fields depending on the month being loaded. It takes C\_TECHBA (old object from PQ1) if month < 01/2018 (kept for reloading purposes) and from C\_TECPC2 if month >= 01/2018. In any case, it takes the attribute C\_REST\_BA (Restated BA) and move to 0G\_CWWE01 (single object in the query for both legacies).

Example:

Calendar Year/Month	Source System	Material	Plant	Company code	Currency	Un Qty invoice	Technical Business A	Tech. Profit Ctr 2	N8110 - Qty Sold	R10000 - Net sales
12.2017	PF1_020	60102	51XB	4290	US Dollar	US pound	F25MKXXXU2429051XB	#/CHEF/#	2.311.420	320.478,51
01.2018	PF1_020	60102	51XB	4290	US Dollar	US pound	#	7250/CHEF/F25MKXXXU2	853.540	119.115,77

if month < 01.2018 - use C\_TECHBA  
if month >= 01.2018 - use C\_TECPC2R

**Data Browser: Table /BIC/PC\_TECHBA:**

/BIC/C_TECHBA	OBJVERS	CHANG...	/BIC/C_REST_BA
F25MKXXXU2429051XB	A		7250

**Data Browser: Table /BIC/PC\_TECPC2R: 1 of 1 Hits**

LOGSYS	/BIC/C_COMP...	/BIC/C_PLANT	BUS_AREA	CO_AREA	/BIC/C_TECPC2R	OBJVERS	/BIC/C_REST_BA
PF1_020	4290	51XB	7250	CHEF	F25MKXXXU2	A	7250

List of APDs:

APD	Source (Query)	(Target) DSO
APD_PL_0010	SPM - APD P&L (Rhodia) - curr + prev month	APD_QRY_MVCOPA01_0010
APD_PL_0011	SPM - APD P&L (Solvay) - curr + prev month	APD_QRY_MVCOPA01_0011
APD_PL_0020	SPM - APD P&L (Rhodia) - any period	APD_QRY_MVCOPA01_0020
APD_PL_0021	SPM - APD P&L (Solvay) - any period	APD_QRY_MVCOPA01_0021

(The last 2 APDs are not scheduled on a regular basis. They were created for reloading purpose, allowing to inform the period to be loaded in the query variant).

### Transformation of data (Derivation of SPM characteristics)

Some mapping tables were created in WBP with maintenance views (restricted to very few users).

The access is done via transaction ZSPM in WBP.

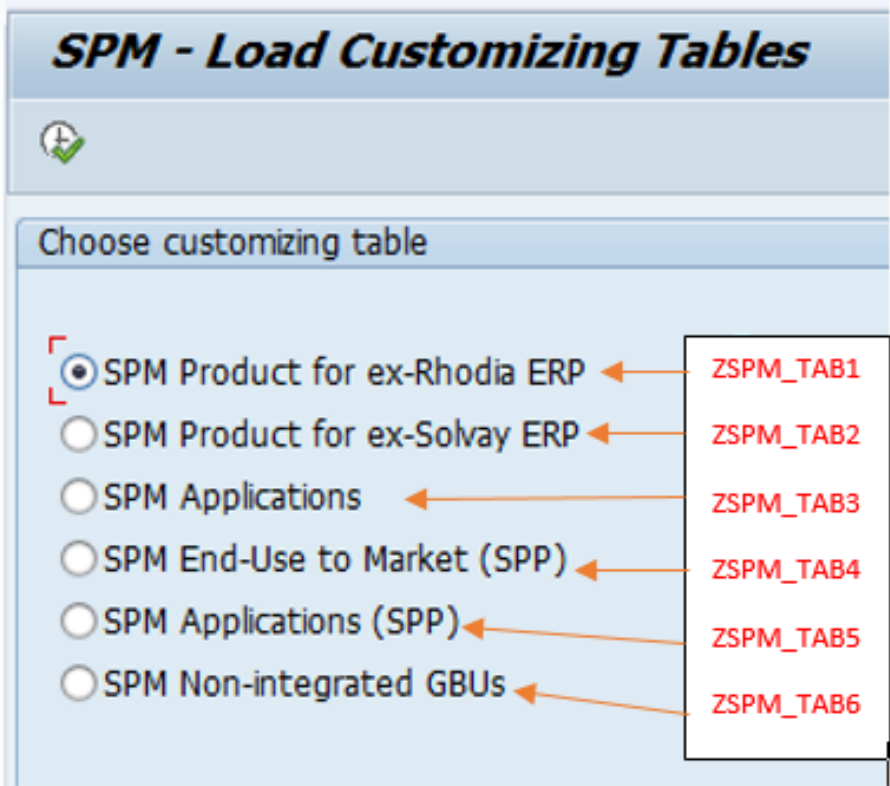

Update on June/2021

- Tables ZSPM\_TAB4 and ZSPM\_TAB5 became obsolete and were removed from this menu
- Authority check based on GBU was implemented to display/edit data
- New transaction for mass upload was created

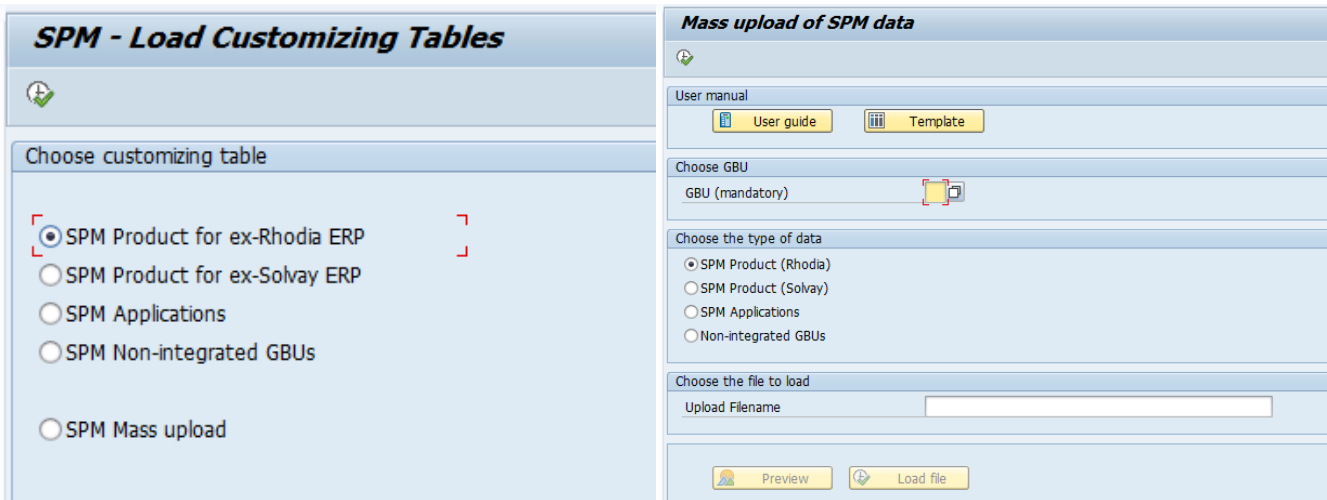

There are basically 3 steps:

### 1) Derive SPM product

For Rhodia Legacy - based on GBU / Group of Activities / Sub-Activity / Product Line 2 / Product Line 0 / Commercial Product

For Solvay Legacy - based on GBU / Group of Activities / Sub-Activity / PIF hierarchy / Product hierarchy / Material Group

Example:

<b>GBU</b>	<b>Group of Activity</b>	<b>Sub Activity</b>	<b>RCS : Line 2</b> PF1 : PIF Hierarchy	<b>RCS : Line 0</b> PF1 : Mat Product Hierarchy	<b>RCS : Coml Product</b> PF1 : Mat Group	<b>SPM Product Code</b>
Aroma Performance	B.U. Diphenol	Inhibitors Solutions	PMP	PMP MOLTEN	*	764

How it's stored in mapping table

#### Maint.view ZSPM\_V1

BFC...	GBU name	BFC BU	BU name	Sub-actvi	Sub-actv name	Line 02	Line 02 name	Line 00	Line 00 name	P.P.	SPM Product	SPM Product name
PA	AROMA PERFORMA...		B.U. DIPHENOL	IECRA01045	INHIBITORS SOLUTIONS					437	Z_Other (Aroma Perfo	
PA	AROMA PERFORMA...	PADIP	B.U. DIPHENOL	IECRA01045	INHIBITORS SOLUTIONS	LIP0201198	TBC			499	TBC	
PA	AROMA PERFORMA...	PADIP	B.U. DIPHENOL	IECRA01045	INHIBITORS SOLUTIONS	LIP0202114	HYDROQUINONE			498	Hydroquinone	
PA	AROMA PERFORMA...	PADIP	B.U. DIPHENOL	IECRA01045	INHIBITORS SOLUTIONS	LIP0202954	PMP			500	PMP	
PA	AROMA PERFORMA...	PADIP	B.U. DIPHENOL	IECRA01045	INHIBITORS SOLUTIONS	LIP0202954	PMP	LIP0020367	PMP MOLTEN	764	PMP Molten	

#### Table ZSPM\_TAB1

**Data Browser: Table ZSPM\_TAB1: 31 of 31 Hits**

Check Table...

MANDT	CPFCTR1_2	CPFCTR2_2	G_CVWE01	C_LIP02	C_LPROD	C_PROD	C_SPMPRO
400	PA						00437
400	PA	PADIP	IECRA01045				00437
400	PA	PADIP	IECRA01045	LIP0201198			00499
400	PA	PADIP	IECRA01045	LIP0202114			00498
400	PA	PADIP	IECRA01045	LIP0202954			00500
400	PA	PADIP	IECRA01045	LIP0202954	LIP0020367		00764
400	PA	PADIP	IECRA01045	LIP0210179			00988

How the derivation is done from a sales record

Source data (P&L query)

Source System	Material	Ship-to party	Calendar Year/Month	Sub-activity	N8110 - Qty Sold	R10000 - Net sales
					KG	EUR
WP1_400	11451	59517	01.2016	IECRA01045	12.020	96.761,00

**Data Browser: Table /BIO/PG\_CWWE01:**

G_CWWE01	/BIC/CPFCTR1_2	/BIC/CPFCTR2_2
IECRA01045	PA	PADIP

**Data Browser: Table /BIC/PC\_MATNR2: 1 of 1 Hits**

LOGSYS	/BIC/C_MATNR2	OBJVERS	/BIC/C_PROD	/BIC/C_LPROD	/BIC/C_LIP02
WP1_400	11451	A	90001717	LIP0020367	LIP0202954

Derive SPM Product

**Important:** the lookup in the mapping tables is done from the most specific case (complete key) to the most generic case, so for example, when reading ZSPM\_TAB1 to get SPM product, it does the following:

1. Search with complete key = GBU + Group of act + Sub-act + Line 2 + Line 0 + Com.prod
2. If not found, search with GBU + Group of act + Sub-act + Line 2 + Line 0 + Com.prod = space
3. If not found, search with GBU + Group of act + Sub-act + Line 2 + Line 0 = space + Com.prod = space
4. and so on ... until the search is done only with GBU + Group of act.

Update on June/2021 -

The SPM product can now be defined by informing directly GBU + com.prod (in ZSPM\_TAB1) or GBU + mat.group (in ZSPM\_TAB2)

2) Derive SPM PAC (Application)

For both legacies, based on SPM product obtained in step 1 + End-Use fields (Market, Application, Segment, End-Use)

Example:

Key	Key	Key	GBR END USE	GBR END USE	GBR END USE	GBR END USE	Key	key	ENTRY	
GBU	SPM Product	SPM Product Name	Market	Segment	Application	End Use	Ship-to	Bus Yea %	SPM PAC Code	SPM PAC Name
Arroma Performa	764	PMP Molten	Industrial Applications	Chemical Industry	Monomers	*	*	*	100	2075 PMP Molten

How it's stored in mapping table

## Maint.view ZSPM\_V3

SPM PAC (Rhodia)														
B... GBU name	SPM...	SPM Prod...	Market code	Market name	Segment c...	Segment name	Appl. code	Appl. name	End use code	E...	Cus...	C. Y.	SPM PAC	Perc
PA AROMA PERFORMANCE	764	PMP Moken	COMAR00010	INDUSTRIAL APPLICATIONS	COSEG00045	CHEMICAL INDUSTRY	COAPP00160	MONOMERS				0	2075	100,000

## Table ZSPM\_TAB3

**Data Browser: Table ZSPM\_TAB3: 3 of 3 Hits**

MANDT	CPFCTR1_2	C_SPMPRO	C_GBR2	C_GBR3	C_GBR1	C_GBR4	C_GBR5	CALYEAR	C_SPMPAC	K_PERC
400	PA	764							2822	100,000
400	PA	764	COMAR00010	COSEG00045	COAPP00160				2075	100,000
400	PA	764	COMAR00011	COSEG00032	COAPP00065	ENDUSEGPA00637			2821	100,000

How the derivation is done from a sales record

## Source data (P&L query)

Source System	Material	Ship-to party	Calendar Year/Month	Sub-activity	N8110 - Qty Sold	R10000 - Net sales
					KG	EUR
WP1_400	11451	59517	01.2016	IECRA01045	12.020	96.761,00

**Data Browser: Table /BIC/PC\_GBR14: 4 of 4 Hits**

LOGSYS	/BIC/C_PROD	/BIC/CPFCTR1_2	/BIC/C_GBR14	OBJVERS	CHANGED	/BIC/C_GBR1	/BIC/C_GBR2	/BIC/C_GBR3	/BIC/C_GBR4
WP1_400	90001658	PA	59517	A		COAPP00160	COMAR00010	COSEG00045	ENDUSEGPA00640
WP1_400	90001716	PA	59517	A		COAPP00160	COMAR00010	COSEG00045	ENDUSEGPA00621
WP1_400	90001717	PA	59517	A		COAPP00160	COMAR00010	COSEG00045	ENDUSEGPA00621
WP1_400	90066857	PA	59517	A		COAPP00160	COMAR00010	COSEG00045	ENDUSEGPA00640

**+ SPM Product from step 1 → Derive SPM PAC**

Update on June/2021 -

In order to assign SPM PAC, the user can inform directly the End-Use, without having to inform Market / Application / Segment in table ZSPM\_TAB3.

C\_GBR14 was replaced by the new C\_GBR34.

## Multiple PACs

We can have multiple PACs assigned to the same combination of GBU + SPM prod + End-Use. In that case, the percentage field will define the split to be done among several PACs, so the routine takes into account this percentage in order to allocate the sales.

## 3) Recalculate SPM product

There are some cases, (for example in Novocare for Agro with "Formulations & Blends" ), that we must **overwrite the SPM product derived in step 1** with the SPM product obtained directly from SPM PAC master data, because it splits in 3 different PACs in table 3, with a different product assigned to each PAC.

So this "recalculation" was implemented in a **recursive transformation** into DSOs DBSDSP02 (Rhodia) and DBSDSP04 (Solvay).

In terms of the data flow, this is where these lookups are implemented

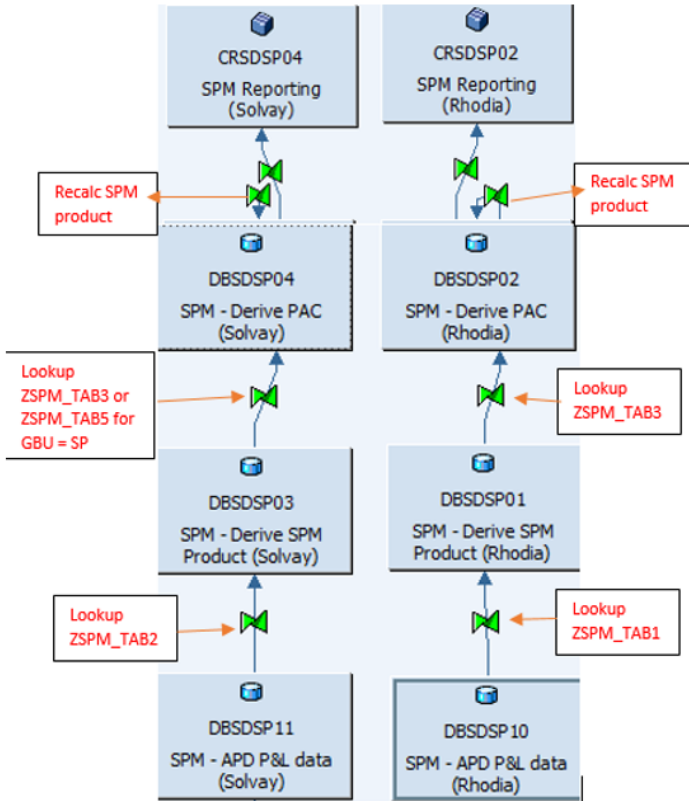

### List of SPM mapping tables

Table	View	Description	Comment
ZSPM_TAB1	ZSPM_V1	SPM Product (Rhodia)	
ZSPM_TAB2	ZSPM_V2	SPM Product (Solvay)	
ZSPM_TAB3	ZSPM_V3	SPM Applications	
ZSPM_TAB4	ZSPM_V4	SPM End-Use to Market (SPP)	Specific to GBU Specialty Polymers
ZSPM_TAB5	ZSPM_V5	SPM Applications (SPP)	Specific to GBU Specialty Polymers
ZSPM_TAB6	ZSPM_V6	SPM Non-integrated GBUs	Only for GBUs where sales doesn't come from P&L

Update on June/2021:

The specific objects developed for SpP described below were decommissioned as SpP started to use the Corporate End-Use in GBR.

### Special case 1 - GBU Specialty Polymers

For GBU Specialty Polymers, sales figures are loaded normally from P&L (sales in PF1) and the derivation of SPM product (step 1) follows the normal SPM flow.

The only difference is in the PAC derivation (step 2) since **Specialty Polymers doesn't use the "Corporate End-Use" (C\_GBR14)**.

They maintain their own End-Use information in Sales Force, so some new objects were created in BW to load this data from Sales Force.

New InfoObjects

▶  Sales Force - End Use Definition	C_SFEU1
▶  Sales Force - End-Use (Sold-to)	C_SFEU2

C\_SFEU1 is loaded with the existing End-Use values in Salesforce (code + text) from an excel file

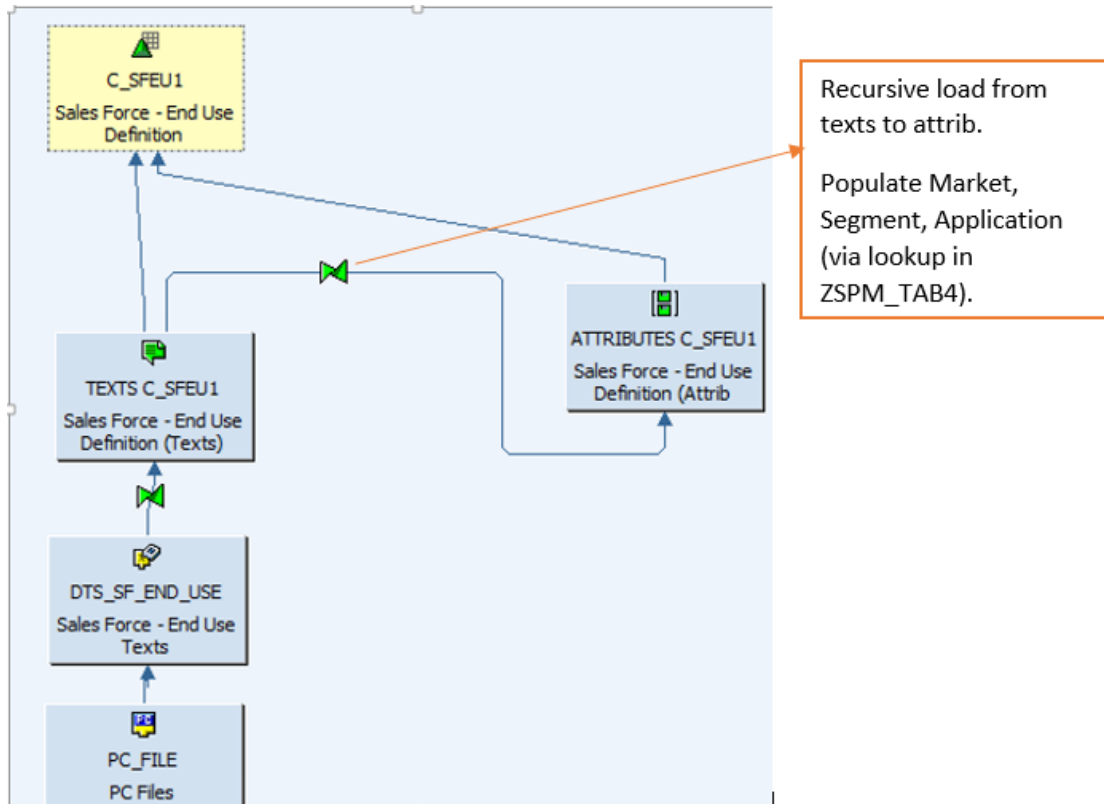

And then updated with attributes below, which are maintained in WBP in table ZSPM\_TAB4.

SF End Use	Medium description	Market	Long description	Segment	Long description	Application	Long description
ABA	AUTO - BATTERIES	COMAR00012	AUTOMOTIVE	COSEG00002	ELECTRIFICATION	COAPP00002	BATTERY SYSTEMS
ACH	CH - AUTO COMPOUNDER	COMAR00012	AUTOMOTIVE	COSEG00034	POWERTRAIN EFFICIENCY	COAPP00137	TRANSMISSION PARTS
ADD	IM - ADDITIVES	COMAR00010	INDUSTRIAL APPLICATIONS	COSEG00018	INDUSTRIAL & PROTECTIVE COATINGS	COAPP00033	INDUSTRIAL COATINGS
ADS	CH - AUTO DISTRIBUTOR	COMAR00012	AUTOMOTIVE	COSEG00034	POWERTRAIN EFFICIENCY	COAPP00137	TRANSMISSION PARTS
ADT	CP - ADDITIVES	COMAR00010	INDUSTRIAL APPLICATIONS	COSEG00018	INDUSTRIAL & PROTECTIVE COATINGS	COAPP00033	INDUSTRIAL COATINGS
AGE	AUTO - GEARS	COMAR00012	AUTOMOTIVE	COSEG00034	POWERTRAIN EFFICIENCY	COAPP00137	TRANSMISSION PARTS
ALE	WC - ALTERNATIVE ENERGY	COMAR00051	ENERGY SOLUTIONS	COSEG00033	POWER GENERATION	COAPP00047	PHOTOVOLTAIC

So this table ZSPM\_TAB4 was created to map the Salesforce End-Use with Corporate "Market / Segment / Application"

Regarding the End-Use link with the customer, in the case of Salesforce, it's done by the sold-to (and not ship-to). Actually, it's done for a SF account ID that can map to N sold-to codes. Also, the product level can vary, can be done at material group (commercial product) or product hierarchy.

So we have the following rules into C\_SFEU2:

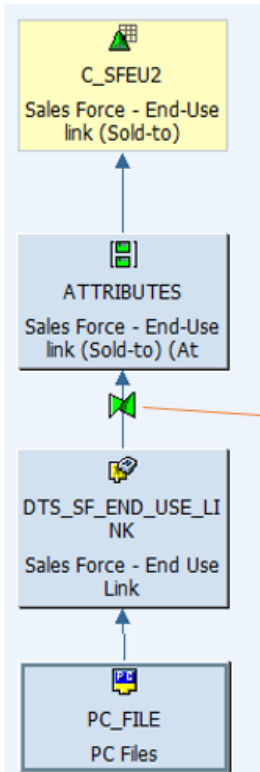

**Rules:**

- Logsys = PF1  

```
CALL FUNCTION 'Z_WBW_SOURCE_SYSTEM'
EXPORTING
  ip_landscape      = 'SOLVAY'
```
- GBU = constant 'SP'
- Product:
  - IF match\_type = 'Product Hierarchy' -> Fill C\_PRDHIER
  - IF match\_type = 'Product' -> Fill C\_PROD
- Sold-to:  
**Map SF account ID to sold-to (1:N) via lookup in table ZSF\_SOLDTOS**

Example of data received from SF (directory /exploit/BW/SPM) and the mapping of SF account to sold-to via table ZSF\_SOLDTOS

Directory: /exploit/BW/SPM  
 Name: END\_USE\_LINK.csv

```
"a2S0e0000005gmzEAA";"EU# 00207765";"0010e00001JvFn7AAF";"Product Hierarchy";;"JECA";"EED";"CH - EE DISTRIBUTOR"
"a2S0e0000005gn0EAA";"EU# 00207766";"0016000000U7EBRAA3";"Product Hierarchy";;"JECB";"OPI";"PI - OTHERS"
"a2S0e0000005gn1EAA";"EU# 00207767";"0010e00001JvlzpAAB";"Product Hierarchy";;"JEDA";"CFL";"PI - COMPONENT/FITTINGS/LININGS"
"a2S0e0000005gn2EAA";"EU# 00207768";"0016000000kZPclAAG";"Product Hierarchy";;"JEDA";"FLS";"PI - FILTRATION/SEPARATION"
"a2S0e0000005gn3EAA";"EU# 00207769";"00160000019L7LxAAK";"Product Hierarchy";;"JEDA";"CFL";"PI - COMPONENT/FITTINGS/LININGS"
```

Take first 15 digits

**Data Browser: Table ZSF\_SOLDTOS:**

MANDT	SOLDTO	ID_SF
400	0004604237	0010e00001JvFn7

For SPM PAC derivation, there is table ZSPM\_TAB5, which assigns a PAC based on GBU + SPM Prod + SF End-Use (C\_SFEU1).

Finally, in SPM query, attributes Market / Segment / Application come from different objects depending on the GBU

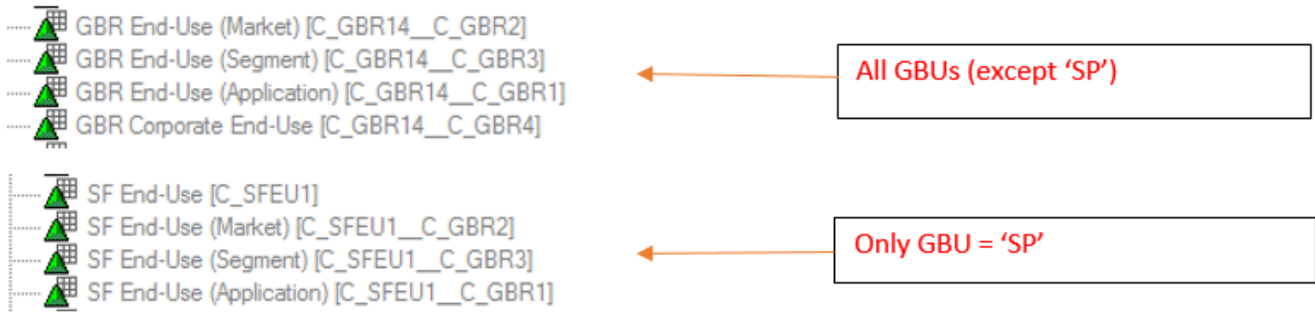

## Special case 2 - Composite Materials

For Composite Materials (and potentially any other GBU not integrated in WP1/PF1 yet), it was developed a "light", temporary solution, where the sales are informed manually, in an aggregated way.

So in table **ZSPM\_TAB6**, user can inform the sales amount directly at this level: by GBU, month, SPM product, SPM PAC, Corporate Group and Corporate End-Use.

Since SPM Product and PAC are manually informed, there are no derivations in this case and the data goes straightforward to cube CRSDSP90, to be combined with the other cubes in MVSDSP01.

Sales amounts must be informed in EUR. There is no quantity (volume) information, and no detail on customer/material.

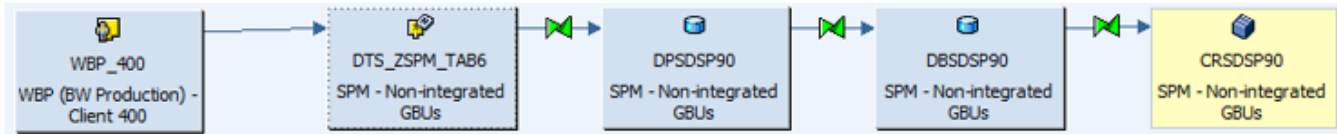

## Master Data from PF7

Update on June/2021 - New source for SPM Master Data is WPE (replacing PF7)

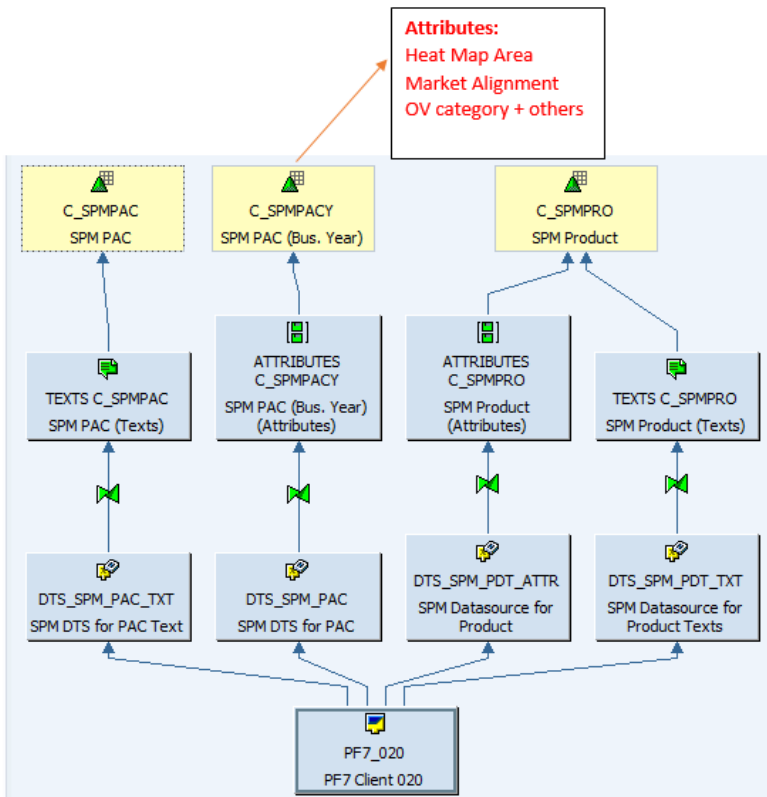

Dependencies with other applications

Data loadings

Info providers and objects loaded

Loading frequency

PC SPM\_MAIN is scheduled daily at 05:00 (CET).

<ul style="list-style-type: none"> <li>SPM - Main Chain</li> </ul>	PC_SPM_MAIN
<ul style="list-style-type: none"> <li>SPM - Master Data</li> </ul>	PC_SPM_MD
<ul style="list-style-type: none"> <li>SPM - Transactional data - Other GBUs</li> </ul>	PC_SPM_TRANS_90
<ul style="list-style-type: none"> <li>SPM - Transactional data - Rhodia</li> </ul>	PC_SPM_TRANS_01
<ul style="list-style-type: none"> <li>SPM - Transactional data - Solvay</li> </ul>	PC_SPM_TRANS_02

The following PCs do not run on a regular basis. They are used only to reload historical data

<ul style="list-style-type: none"> <li>SPM - Reload Rhodia</li> </ul>	PC_SPM_RELOAD_01
<ul style="list-style-type: none"> <li>SPM - Reload Solvay</li> </ul>	PC_SPM_RELOAD_02

They execute the corresponding APDs,

PC		APD	Query	Variant
PC_SPM_RELOAD_01	SPM - Reload Rhodia	APD_PL_0020	APD_QRY_MVCOPA01_0020	ZAPD_VAR_0020
PC_SPM_RELOAD_02	SPM - Reload Solvay	APD_PL_0021	APD_QRY_MVCOPA01_0021	ZAPD_VAR_0021

So for example, if we need to reload P&L data for Rhodia (WP1) for 2018, just update the variant in RSRT as follows and trigger the PC to reload.

APD: BW P&L data for SPM (Rhodia) - any period

Conso. view? (1=Yes/0=No) (\*)

Target Currency  Empty Selection

Source System (Selection Option, Mandatory) (\*) =  To

Calendar Month/Year (Interval, Optional)  To

1 - BFC GBU (Clt) (Selection Opt, Optional) =  To

This will take data up to business layer, then it will go the cubes with the regular daily load.

## Average performance

Key Figure	Estimation
~ Average Process Chain Runtime	<b>35 minutes</b>
~ Average nb of rows loaded per load	
~ Total nb of rows loaded (if full)	
~ Average Runtime for 10k lines	

## Record Keeping

SPM keeps current year + 3 previous years.

This is controlled with a routine in the DTPs into DSOs DBSDSP01 (Rhodia) and DBSDSP03 (Solvay)

## Reporting

### Queries End User Documentation

### Main queries

Queries:

- **BW\_QRY\_MVSDSP01\_0001** - Core query
- **QV\_BW\_QRY\_MVSDSP01\_0001** - copy used for QlikView

### Main functionalities

Broadcast

Maintenance



Known bugs

Recurring procedure

Planned Evolution

## Workflow history

This view shows the 5 most recent entries. The complete workflow log is available from the 'Document Activity' menu item.

From Mar 04, 2019 to Nov 06, 2023	Actor	Type	Activity	Version
	<a href="#">GIRAUD-ext, Mickael and Laressa MORETTI</a>	Edit	multiple updates from  <a href="#">GIRAUD-ext, Mickael and Laressa MORETTI</a>	
	 <a href="#">Laressa MORETTI</a>	Edit	created the page at 7:19 pm	