

# BW PtP - Sprint Contract Price change /\ Obsolete /\



The new wiki link for this data flow is here:

[Technical Documentation - Procurement - SPRINT report](#)

Please update the new doc there and no longer here.



- General presentation
  - Objective of the application
  - Usage information
  - History
- Roles & Access
  - Roles and access
- Dataflow overview
  - Functional and Technical rules on Workbench + Reporting
  - Rules & Explanations
  - Dependencies with other applications
- Data loadings
  - Info providers and objects loaded
  - Loading frequency
  - Average performance
  - Record Keeping
- Reporting
  - Queries End User Documentation
  - Main queries
  - Main functionalities
  - Broadcast
- Maintenance
  - Known bugs
  - Recurring procedure
  - Planned Evolution

## General presentation

### Objective of the application

This report / application is to track the **Contract** price change information by change date. This information is gathered using the change document details. There is no report in ECC which can give this information.

Tool Leader + IT leader of the application:

Reporting Coordinator : Duarte Costa (Lisbon)

Purchasing Data and P-t-P Interface Manager : Sylvie Severini (Brussels)

### Usage information

D&A and buyers are the key users of this report

### History

Business requested a BW report that can provide a structure similar to the above mentioned reports in PF1 and WP1 and that is able to provide the price changes per material Base Unit of Measure and also per last condition record unit of measure considering changes done not only to the condition records but the Price Unit information and its quantity conversions.

Requestor: Rui Cabrita

## Roles & Access

### Roles and access

List of application role + menu role and explanation if we have several applications role with specials rules.

Role Code	Role Description	Explanation
ZR_RCS_CA_M04	SPRINT - Purchasing	Role menu ZR_RCS_CA_M04 uses application role ZR_RCS_SPRINT2_A01 linked to IA_PUR_SPRINT* Authorization Object ZBI_SPRINT2 / Authorization on zone, GBU, Plant.

## Authorization objects

List of autorisation objects mandatory for the application.

Authorization object	Explanation
Plant (C_PLANT)	ZR_*_CA_P02 ZR_7866_CA_P02 => Plant 7866 - Chalampé (ex 7027) - (Cie ZFR9) ZR_TOUT_CA_P02 => All Plants "Solvay"

## Dataflow overview

The key logic was built in extractor. The extraction logic was built in such a way that the relevant field's (that affect the price changes) old value and new value should be captured in the extraction.

But, the key challenge is we always have the latest values in the tables. Previous values can only be captured using the change documents (CDHDR & CDPOS).

Example:

If Purchase order unit of measure (EKPO-MEINS) changed from KG to TO...

We will have the value "TO" in the table EINA. But to get the previous value (KG), we need to scan through all the change documents for that Contract.

Extraction logic:

Only the below list of fields are considered for price differences calculations.

EKKO:

EBELN  
 BSTYP  
 EKORG  
 LOEKZ  
 AEDAT  
 ERNAM  
 LIFNR  
 EKGRP  
 WAERS

EKPO:

EBELN  
 EBELP  
 LOEKZ  
 MATNR  
 MATKL  
 UMREZ  
 UMREN  
 LMEIN  
 WERKS  
 NETPR  
 PEINH  
 MEINS  
 BPRME  
 PRDAT  
 BPUMZ  
 BPUMN

Using the function module "CHANGEDOCUMENT\_READ", the extractor picks the change documents of the given date range. Only by keeping the above 12 field's changes, remaining changed were discarded.

In that selected documents, for each change document and its contract, the subsequent document will be verified in the same list that was selected. If the subsequent document found in the selected list, we will read that document to capture both old & new values. Old values are considered from old change document number and the new value considers from the next available subsequent change document for the same PIR.

If the subsequent document is not found in the initially selected documents, the program again scans for the next available change document of the contract number. This way of scanning continues for all the relevant 12 fields changes are found. Using both the change documents, it captures both old values & new values of each change document. If subsequent change document is not found for any of the contract, it means; that particular contract is not changed after. It means, the existing value for that contract is the new value for that field.

After capturing the both old & new values of each contract & change document, the extractor gets the outcome in below format.

Data Package (Number of Recs)														
1 (559)														
Object Value Doc. no.	User	Date	Time	TCode	Table	Table Key	Old value	New value	Old value	New value	Old value	New value	Old value	New value
4700001673	434276173	PT63015832	01.02.2021	09:47:02	ME32K	EKPO 400470000167300810	ST	1	1	1	1	1	ST	ST 13,89 EUR 14,12 EUR
5500005644	434278239	RALBY	01.02.2021	10:03:24	ME32L	EKPO 400550000564400010	TO	TO	1	1	1	1	TO	TO 908,00 EUR 824,00 EUR
4600001141	434278304	FDELORME	01.02.2021	10:04:27	ME32K	EKPO 400460000114100010	TO	TO	1	1	1	1	TO	TO 908,00 EUR 908,00 EUR
4600001141	434278411	FDELORME	01.02.2021	10:05:02	ME32K	EKPO 400460000114100010	TO	TO	1	1	1	1	TO	TO 908,00 EUR 824,00 EUR
4600001141	434278553	FDELORME	01.02.2021	10:05:41	ME32K	EKPO 400460000114100020	TO	TO	1	1	1	1	TO	TO 908,00 EUR 824,00 EUR
4700001514	434298436	PINT3661	01.02.2021	12:21:39	ME32K	EKPO 400470000151402010	ST	ST	1	1	1	1	ST	ST 20,24 EUR 2,42 EUR
4700001514	434302937	PT63015832	01.02.2021	12:55:06	ME32K	EKPO 400470000151404400	ST	ST	1	1	1	1	ST	ST 26,47 EUR 29,10 EUR
4700002555	434311095	PT63015832	01.02.2021	14:00:32	ME32K	EKPO 400470000255500490	ST	ST	1	1	1	1	ST	ST 1,40 EUR 2,20 EUR
4600002015	434311950	BERN6529	01.02.2021	14:08:46	ME32K	EKPO 400460000201500030	EA	EA	1	1	1	1	EA	EA 186.126,45 BRL 289.730,00 BRL
4600002319	434312047	BERN6529	01.02.2021	14:09:26	ME32K	EKPO 400460000231900010	ST	ST	1	1	1	1	ST	ST 4.855,00 BRL 5.063,85 BRL
4600001867	434312251	BERN6529	01.02.2021	14:11:07	ME32K	EKPO 400460000186700350	EA	EA	1	1	1	1	EA	EA 13.006.368,68 BRL 14.131.766,25 BRL
5500005484	434318213	SATU8722	01.02.2021	14:43:16	ME32L	EKPO 400550000548400010	ST	ST	1	1	1	1	ST	ST 38.180,00 BRL 43.143,40 BRL
4600002319	434319783	BERN6529	01.02.2021	14:51:47	ME32K	EKPO 400460000231900010	ST	ST	1	1	1	1	ST	ST 5.063,85 BRL 3.532.012,50 BRL
5500005626	434324666	BRBC3964	01.02.2021	15:17:40	ME32L	EKPO 400550000562600010	KGW	KGW	500	500	1000	1000	KG	KG 1.912,07 BRL 1.963,49 BRL
5500005625	434325064	BRBC3964	01.02.2021	15:19:37	ME32L	EKPO 400550000562500010	KGW	KGW	499	499	1000	1000	KG	KG 1.838,20 BRL 1.886,60 BRL
5500005443	434329908	BRBC3964	01.02.2021	15:34:37	ME32L	EKPO 400550000544300010	KG	KG	1	1	1	1	KG	KG 5.904,00 BRL 6.661,00 BRL
4600002593	434331198	NBASHERI	01.02.2021	15:44:08	ME32K	EKPO 400460000259300020	LB	LB	22046	22046	10000	10000	KG	KG 63,91 63,91
5500005637	434335399	BRBC3964	01.02.2021	16:13:56	ME32L	EKPO 400550000563700010	TO	TO	1	1	1000	1000	KG	KG 654,45 BRL 660,33 BRL
5500005639	434335510	BRBC3964	01.02.2021	16:15:19	ME32L	EKPO 400550000563900010	TO	TO	1	1	1000	1000	KG	KG 654,45 BRL 660,33 BRL
5500005638	434335520	BRBC3964	01.02.2021	16:15:03	ME32L	EKPO 400550000563800010	TO	TO	1	1	1000	1000	KG	KG 654,45 BRL 660,33 BRL
4700002163	434340522	NBASHERI	01.02.2021	16:53:48	ME32K	EKPO 400470000216300150	EA	EA	1	1	1	1	ST	ST 35,32 USD 38,78 USD
4700002163	434340715	NBASHERI	01.02.2021	16:54:39	ME32K	EKPO 400470000216300070	ST	ST	1	1	1	1	ST	ST 34,21 USD 36,54 USD
4700002163	434340862	NBASHERI	01.02.2021	16:56:55	ME32K	EKPO 400470000216300160	EA	EA	1	1	1	1	ST	ST 49,18 USD 54,78 USD
4700000045	434340988	PT63015832	01.02.2021	16:57:47	ME32K	EKPO 400470000004500590	ST	ST	1	1	1	1	ST	ST 1,98 EUR 2,83 EUR

Old value	New value	Old value	New value	Old value	New value	Old value	New value	Old value	New value	Old value	New value	Purch.Doc.	Vendor	Material	POrg	Plant	PGr	Crcy
EUR	EUR	1	1	ST	ST	1	1	1	1	31.12.9999	31.12.9999	4700001673	123874	1903635	3002	7622	YJQ	EUR
EUR	EUR	1	1	TO	TO	1	1	1	1	99991231	99991231	5500005644	61053	10735	3006	7681	FJT	EUR
EUR	EUR	1	1	TO	TO	1	1	1	1	25.02.2021	25.03.2021	4600001141	61053	10735	3006	7681	E03	EUR
EUR	EUR	1	1	TO	TO	1	1	1	1	25.02.2021	25.02.2021	4600001141	61053	10735	3006	7681	E03	EUR
EUR	EUR	1	1	TO	TO	1	1	1	1	25.02.2021	25.03.2021	4600001141	61053	10735	3006	7681	E03	EUR
EUR	EUR	10	10	ST	ST	1	1	1	1	31.12.9999	31.12.2030	4700001514	117136	1011540	3004		YZZ	EUR
EUR	EUR	1	1	ST	ST	1	1	1	1	31.12.9999	31.12.9999	4700001514	117136	1015212	3004		YZZ	EUR
EUR	EUR	1	1	ST	ST	1	1	1	1	31.12.9999	31.12.9999	4700002555	102137592	1013490	3004		YYY	EUR
BRL	BRL	1000	1000	EA	EA	1	1	1	1	99991231	99991231	4600002015	83308	1659209	3020	7515	E72	BRL
BRL	BRL	1000	1000	TH	TH	1000	1000	1	1	99991231	99991231	4600002319	2500041711	1909331	3018	8287	E58	BRL
BRL	BRL	1000	1000	EA	EA	1	1	1	1	99991231	99991231	4600001867	81294	1843792	3020	7525	YKL	BRL
BRL	BRL	1000	1000	EA	EA	1	1	1	1	00000000	00000000	5500005484	84214	1671090	3018	7525	E58	BRL
BRL	BRL	1000	1000	TH	TH	1000	1000	1	1	99991231	99991231	4600002319	2500041711	1909331	3018	8287	E58	BRL
BRL	BRL	1000	1000	KGW	KGW	1	1	1	1	00000000	00000000	5500005626	2500047833	73369	3022	7525	E84	BRL
BRL	BRL	1000	1000	KGW	KGW	1	1	1	1	00000000	00000000	5500005625	2500047833	110628	3022	7525	E84	BRL
BRL	BRL	1000	1000	KG	KG	1	1	1	1	20170901	20170901	5500005443	85437	97398	3022	7525	E84	BRL
USD	USD	100	100	LB	LB	1	1	1	1	28.02.2021	15.03.2021	4600002593	117204	61473	3014	8056	EFS	USD
BRL	BRL	1	1	TO	TO	1	1	1	1	20201223	20201223	5500005637	2500047616	61463	3022	7525	E84	BRL
BRL	BRL	1	1	TO	TO	1	1	1	1	20201223	20201223	5500005639	2500049538	61463	3022	7525	E84	BRL
BRL	BRL	1	1	TO	TO	1	1	1	1	20201223	20201223	5500005638	2500049538	61463	3022	7525	E84	BRL
USD	USD	1	1	EA	EA	1	1	1	1	20210630	20210630	4700002163	104508	1825597	3010	0263	EEW	USD
USD	USD	1	1	ST	ST	1	1	1	1	20210630	20210630	4700002163	104508	1825589	3010	0242	EEW	USD
USD	USD	1	1	EA	EA	1	1	1	1	20210630	20210630	4700002163	104508	1825580	3010	0269	EEW	USD
EUR	EUR	1	1	ST	ST	1	1	1	1	99991231	99991231	4700000045	51947	1088717	3004		YAG	EUR

Each record represents the above said 12 fields old and new values at change document level.

The extractor is available in both the Solvay & Rhodia systems (WP1 & PF1)

**Note:** Extractor brings both contracts as well as Scheduling agreement information. It will not consider purchase order information.

**BW Data model:**

Just for the sake of quick understanding here is the field mapping details between data source fields & BW info objects

C\_O\* Old Value

C\_N\* New Value

APPURCNT1		ABPURCNT1	
C_O_MEINS	PO Unit of Measure	OPO_UNIT	
C_N_MEINS		OUNIT	
C_O_UMREN	Denominator	ODENOMINTR	
C_N_UMREN		K_DENMNTR	
C_O_UMREZ	Numerator	ONUMERATOR	
C_N_UMREZ		K_NUMERTR	
C_O_LMEIN	Base Unit of Measure	OBASE_UOM	
C_N_LMEIN		C_BASUOM2	
C_O_NETPR	Net Price in PIR	ONETPRICE	OLOC_CURRCY
C_N_NETPR		ONET_PRICE	ODOC_CURRCY
C_O_WAERS	Currency	OORDER_CURR	
C_N_WAERS		OCURRENCY	
C_O_PEINH	Price Unit	OPRICE_UNIT	
C_N_PEINH		K_PEINH	
C_O_BPRME	Order Price Unit	C_OP_UNIT	
C_N_BPRME		C_FNEWUNT	
C_O_BPUMN	Denominator1	K_BPUMN	
C_N_BPUMN		K_DNMNTR1	
C_O_BPUMZ	Numerator1	K_BPUMZ	

C_N_BPUMZ		K_NUMRTR1	
C_O_PRDAT	Validity date	C_PRDAT	
C_N_PRDAT		C_LPRDAT	
U_DEV_FIA	Vendor Currency	U_DEV_FIA	

Data Flow Display for CompositeProvider CPPURCNT1

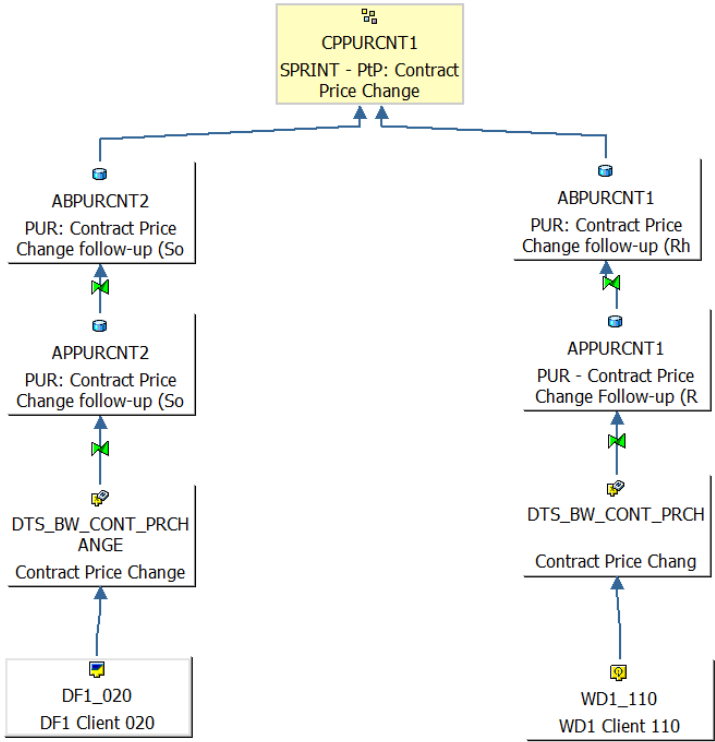

SPRINT - PtP: Contract Price Change	CPPURCNT1
PUR: Contract Price Change follow-up (Rhodia) (business)	ABPURCNT1
ADSO APPURCNT1 -> ADSO ABPURCNT1	0AQLL3JCTSY3HU5KEBKIIICB4NWA94EJ
PUR - Contract Price Change Follow-up (Rhodia)	APPURCNT1
RSDS DTS_BW_CONT_PRCHANGE WD1_110 -> A	0GDFBHAJKN6UR5JUPM1ND42VHI02PFDI
Contract Price Chang	DTS_BW_CONT_PRCHANGE
Delta - DTS_BW_CONT_PRCHANGE	ZPAK_5ODEY1JZ980UO242ZIJMJNHGQ
Full - DTS_BW_CONT_PRCHANGE	ZPAK_5OD8N03GNIY1NAXACKKC49TT6
Data Transfer Processes	APPURCNT1
DTS_BW_CONT_PRCHANGE / WD1_110 -> A	DTP_B1FNYSNDTRTQFBIM6V08YF380
Data Transfer Processes	ABPURCNT1
APPURCNT1 -> ABPURCNT1 - Delta	DTP_B1FNYSNDTRTQFBIP6L1CXOXE8
PUR: Contract Price Change follow-up (Solvay) (business)	ABPURCNT2
ADSO APPURCNT2 -> ADSO ABPURCNT2	06HMXTQ3QLE51PYC45YDCG4YPNHGSYU6
PUR: Contract Price Change follow-up (Solvay)	APPURCNT2
RSDS DTS_BW_CONT_PRCHANGE DF1_020 -> A	00H6FR3NZOUTFV7O1865FREGOIR2BM56
Contract Price Change	DTS_BW_CONT_PRCHANGE
Delta - DTS_BW_CONT_PRCHANGE	ZPAK_5ODIVNHPUM5R77VIHQVZ5YC6I
Full - DTS_BW_CONT_PRCHANGE	ZPAK_5ODA1KCLXHBYIPS945C6RRKFE
Data Transfer Processes	APPURCNT2
DTS_BW_CONT_PRCHANGE / DF1_020 -> A	DTP_B1FNYSNDTRTQFBIT097UUGTN4
Data Transfer Processes	ABPURCNT2
APPURCNT2 -> ABPURCNT2 - Delta	DTP_B1FNYSNDTRTQFBIRJJ9LWTNGW

Extractor brings the data in to BW with both old & new values of the Contract at change document level.

The extraction data mapped to the propagation layer DSO, as it is.

The business logic and calculations are built in between propagation layer & business layer ADSO's. This include the currency conversions also. Since the conversion is based on the document change date, the currency conversion calculations are done at the transformation level using the conversion rate "CAR1".

#### Reporting documentation drive folder:

<https://drive.google.com/drive/folders/1OG6Qn8xEbrO-GKGPWyrPkQ1BtHkS6l1L>

## Functional and Technical rules on Workbench + Reporting

### Rules & Explanations

All the KPI calculations are explained in this section

All the below calculations are performed in below two transformation's end routine.

ADSO APPURCNT1 -> ADSO ABPURCNT1

ADSO APPURCNT2 -> ADSO ABPURCNT2

1. Old Price in Order Price Unit in Info record currency = Old Net Price / Old Price Unit

```
IF <result_fields>-price_unit IS NOT INITIAL.
  <result_fields>-/bic/k_iropop = <result_fields>-netprice /
  <result_fields>-price_unit.
ENDIF.
<result_fields>-/bic/c_curr_1 = <result_fields>-loc_currcy.
```

2. New Price in Order Price Unit in Info record currency = New Net Price / New Price Unit

```

IF <result_fields>-/bic/k_peinh IS NOT INITIAL.
  <result_fields>-/bic/k_iropnp = <result_fields>-net_price /
  <result_fields>-/bic/k_peinh.
ENDIF.

```

3. Delta % in point 1 & 2 = (1 - 2) / 1

```

IF <result_fields>-/bic/k_iropnp IS NOT INITIAL.
  <result_fields>-/bic/k_delpup = (
  <result_fields>-/bic/k_iropnp
  - <result_fields>-/bic/k_iropop ) /
  <result_fields>-/bic/k_iropnp.
ENDIF.

```

4. Delta in point 1 & 2 = (1 - 2)

```

<result_fields>-/bic/k_delpup = ( <result_fields>-/bic/k_iropnp
- <result_fields>-/bic/k_iropop ).

```

5. Old price in base UoM in info record currency

```

IF <result_fields>-base_uom IS NOT INITIAL AND
  <result_fields>-/bic/c_op_unit IS NOT INITIAL.
  IF <result_fields>-base_uom = <result_fields>-/bic/c_op_unit.
    IF <result_fields>-price_unit IS NOT INITIAL.
      <result_fields>-/bic/k_irbuop = <result_fields>-netprice /
      <result_fields>-price_unit.
    ENDIF.
  ELSEIF ( <result_fields>-/bic/c_op_unit <>
    <result_fields>-base_uom ) AND
    ( <result_fields>-/bic/c_op_unit =
    <result_fields>-po_unit ) AND
    <result_fields>-numerator IS NOT INITIAL.
    IF <result_fields>-denomintr IS NOT INITIAL AND
      <result_fields>-price_unit IS NOT INITIAL.
      <result_fields>-/bic/k_irbuop =
      ( <result_fields>-netprice / <result_fields>-price_unit )
      * ( <result_fields>-denomintr / <result_fields>-numerator ).
    ENDIF.
  ELSEIF ( <result_fields>-/bic/c_op_unit <>
    <result_fields>-base_uom ) AND
    ( <result_fields>-/bic/c_op_unit <>
    <result_fields>-po_unit ) AND
    <result_fields>-numerator IS NOT INITIAL.
    IF <result_fields>-denomintr IS NOT INITIAL AND
      <result_fields>-price_unit IS NOT INITIAL AND

```

```

    <result_fields>-price_unit IS NOT INITIAL AND
    <result_fields>-/bic/k_bpumn IS NOT INITIAL.
  <result_fields>-/bic/k_irbuop =
    ( <result_fields>-netprice / <result_fields>-price_unit )
  * ( <result_fields>-denomintr / <result_fields>-numerator )
  * ( <result_fields>-/bic/k_bpumz /
    <result_fields>-/bic/k_bpumn ).
  ENDIF.
ENDIF.
ENDIF.

```

6. New price in base UoM in info record currency

```

IF <result_fields>-/bic/C_BASUOM2 IS NOT INITIAL AND
  <result_fields>-/bic/C_FNEWUNT IS NOT INITIAL.
IF <result_fields>-/bic/C_BASUOM2 =
<result_fields>-/bic/C_FNEWUNT.
  IF <result_fields>-/bic/K_PEINH IS NOT INITIAL.
    <result_fields>-/bic/k_irbunp =
    <result_fields>-net_price /
    <result_fields>-/bic/K_PEINH.
  ENDIF.
ELSEIF ( <result_fields>-/bic/C_FNEWUNT <>
  <result_fields>-/bic/C_BASUOM2 ) AND
  ( <result_fields>-/bic/C_FNEWUNT =
  <result_fields>-unit ) AND
  <result_fields>-/bic/K_NUMERTR IS NOT INITIAL.
IF <result_fields>-/bic/K_DENMNTR IS NOT INITIAL AND
  <result_fields>-/bic/K_PEINH IS NOT INITIAL.
  <result_fields>-/bic/k_irbunp =
  ( <result_fields>-net_price /
  <result_fields>-/bic/K_PEINH )
  * ( <result_fields>-/bic/K_DENMNTR /
  <result_fields>-/bic/K_NUMERTR ).
  ENDIF.
ELSEIF ( <result_fields>-/bic/C_FNEWUNT <>
  <result_fields>-/bic/C_BASUOM2 ) AND
  ( <result_fields>-/bic/C_FNEWUNT <>
  <result_fields>-unit ) AND

```

```

        <result_fields>-/bic/K_NUMERTR IS NOT INITIAL.
    IF <result_fields>-/bic/K_DENMNTR IS NOT INITIAL AND
        <result_fields>-/bic/K_PEINH IS NOT INITIAL AND
        <result_fields>-/bic/K_DNMNTR1 IS NOT INITIAL.
    <result_fields>-/bic/k_irbunp =
        ( <result_fields>-net_price /
          <result_fields>-/bic/K_PEINH )
    * ( <result_fields>-/bic/K_DENMNTR /
        <result_fields>-/bic/K_NUMERTR )
    * ( <result_fields>-/bic/K_NUMRTR1 /
        <result_fields>-/bic/K_DNMNTR1 ).
    ENDIF.
ENDIF.
ENDIF.

```

7. Delta % of Old price in base UoM in info record currency & New price in base UoM in info record currency

```

    IF <result_fields>-/bic/k_irbuop IS NOT INITIAL.
        <result_fields>-/bic/k_delpbp = (
            <result_fields>-/bic/k_irbunp - <result_fields>-/bic/k_irbuop
        ) / <result_fields>-/bic/k_irbuop.
    ENDIF.

```

8. Delta in Old price in base UoM in info record currency & New price in base UoM in info record currency

```

    IF <result_fields>-/bic/k_irbuop IS NOT INITIAL.
        <result_fields>-/bic/k_delcbp = (
            <result_fields>-/bic/k_irbunp - <result_fields>-/bic/k_irbuop
        ).
    ENDIF.

```

9. Old Price in Order Price Unit in Vendor Currency

```

    IF <result_fields>-loc_currcy = <result_fields>-/bic/u_dev_fia.
        <result_fields>-/bic/k_opvcop = <result_fields>-netprice.
        <result_fields>-/bic/c_vcurr = <result_fields>-/bic/c_curr_1.
    ELSE.

```

Convert the NETPRICE to vendor currency using FM "Convert\_To\_Foreign\_Currency"

10. New Price in Order Price Unit in Vendor Currency

Convert the NET\_PRICE to vendor currency using FM "Convert\_To\_Foreign\_Currency"

11. Delta % of old & New order price Unit in vendor currency

Convert the K\_DELPUP to vendor currency using FM "Convert\_To\_Foreign\_Currency"

12. Delta of old & New order price Unit in vendor currency

Convert the K\_DELCUP to vendor currency using FM "Convert\_To\_Foreign\_Currency"

13. Old price in base UoM in Vendor currency

Convert the K\_IRBUOP to vendor currency using FM "Convert\_To\_Foreign\_Currency"

14. New price in base UoM in Vendor currency

Convert the K\_IRBUNP to vendor currency using FM "Convert\_To\_Foreign\_Currency"

15. Delta % of Old price in base UoM in Vendor currency & New price in base UoM in Vendor currency

Convert the K\_IRBUOP to vendor currency using FM "Convert\_To\_Foreign\_Currency"

16. Delta in Old price in base UoM in Vendor currency & New price in base UoM in Vendor currency

Convert the K\_IRBUNP to vendor currency using FM "Convert\_To\_Foreign\_Currency"

## Dependencies with other applications

This is an independent data model and do not dependent on any applications

## Data loadings

Info providers and objects loaded

SPRINT - PtP: Contract Price Change	CPPURCNT1
PUR: Contract Price Change follow-up (Rhodia) (business)	ABPURCNT1
ADSO APPURCNT1 -> ADSO ABPURCNT1	0AQLL3JCTSY3
PUR - Contract Price Change Follow-up (Rhodia)	APPURCNT1
Data Transfer Processes	ABPURCNT1
PUR: Contract Price Change follow-up (Solvay) (business)	ABPURCNT2
ADSO APPURCNT2 -> ADSO ABPURCNT2	06HMXTQ3QLE
PUR: Contract Price Change follow-up (Solvay)	APPURCNT2

Process Chain: PC\_SPRINT\_CONT1

Loads to this info providers are added at end of the process chain PC\_SPRINT\_CONT1

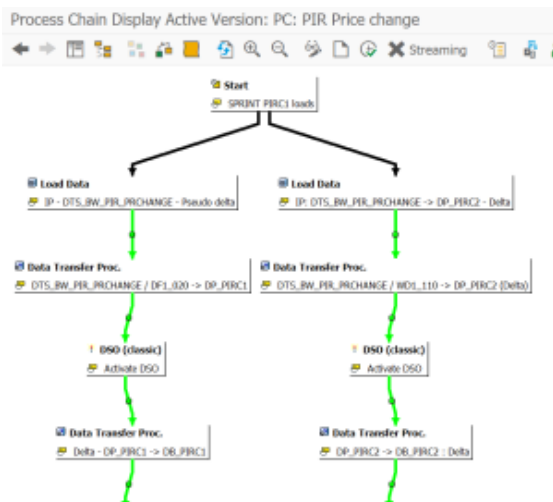

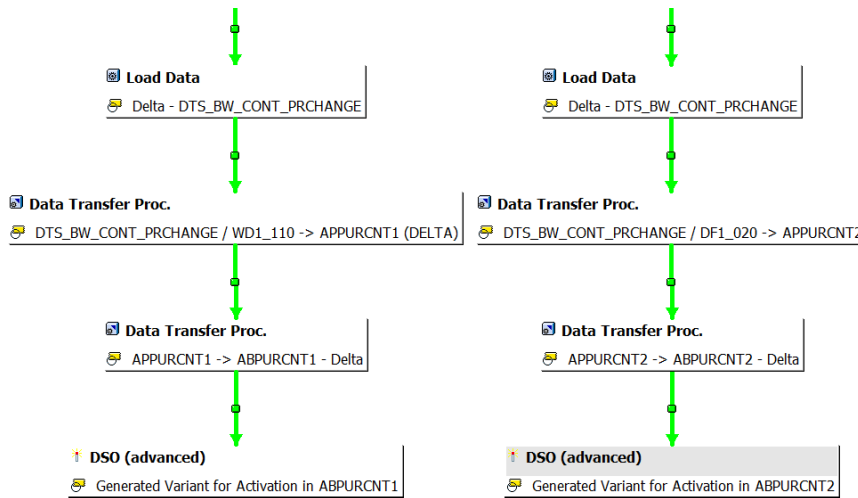

## Loading frequency

Daily loads (except week end) using pseudo delta with current day - 4 days logic

## Average performance

Key Figure	Estimation
~ Average Process Chain Runtime	2 Mins
~ Average nb of rows loaded per load	100 - 200
~ Total nb of rows loaded (if full)	
~ Average Runtime for 10k lines	

## Record Keeping

Data loaded from 2018 - till date

## Reporting

### Queries End User Documentation

## Main queries

The core Query:

BW\_QRY\_CPPURCNT1\_0001 - SPRINT - PUR : Contract Price Analysis (Core Query)

**Filters:**

- + Source System
- + Contract Change Date
- + Contract / Scheduling Agreement
- + Vendor
- + Purchasing Organization
- + Material
- + Plant
- + Purchasing Group
- + Contract Change User
- + Global Business Unit
- + Authorization Scope
- + Vendor Domain (P)
- + Vendor Segment (P)
- + Material Group Domain (P)
- + Material Group Segment (P)

Rows:

-  **Rows**
- Source System
  - Contract / Scheduling Agreement
  - Change Number

Columns:

**Columns**

Key Figures

- Old Price in Contract in Ord PU
- Net price
- New Price in Contract in Ord PU
- Net price
- Delta % (New - Old) Price in Contract in Ord PU
- Delta (New-Old) Price in Contract in Ord PU
- Old Unit Price in Base UoM
- Old Price - IR BUoM
- New Unit Price in Base UoM
- New Price - IR BUoM
- Delta % (Old - New) Unit Price in Contract in BUoM
- Delta
- Delta (Old - New) Unit Price in Contract in BUoM
- Delta
- Old Ord Pr in Vend Curr
- Ord Pr in Vend Curr
- New Ord Pr in Vend Curr
- Ord Pr in Vend CurrN
- Delta % Ord Pr in Vendor Curr
- Delta in Ord Pr Vendor Curr
- Old Unit Ord Pr in BUoM VC

- Ord Pr in BUoM VC
- New Unit Ord Pr in BUoM VC
- Ord Pr in BUoM VCN
- Delta % (New-Old) Unit Price in BUoM Vend Curr
- Delta (New-Old) Unit Price in BUoM Vend Curr

All the key figures are displayed without dimensions (units) as requested by business

**Exceptions:**

As per the business requirement, there are two exceptions in the query to show in different color where...

Delta variance is greater than 5%

Variance greater than 200

**Exceptions**

- Exceptions
  - Delta Variance > 5 %
  - Variance > 200

Exception Is Active

**Description**

Delta Variance > 5 %

**Define Exception Values**

Alert Level	Operator	Values
Bad 1	[GT] Greater Than	5

Exception Is Active

**Description**

Variance > 200

**Define Exception Values**

Alert Level	Operator	Values
Bad 1	[GT] Greater Than	200

Selection Screen:

Specify Value for Prompts

Source System (Several Single values, Optional)	WP1_400		
	PF1_020		
* Time (From... to...) (Interval, Mandatory)			
Contract	=		
Plant (Selection Option, Optional)	=		
Purchasing Organization	=		
Purchasing Group	=		
Vendor (Selection Option, Optional)	=		
Vendor Domain (P)	=		
Vendor Segment (P)	=		
Material (Selection Option, Optional)	=		
Material Group Domain (P)	=		
Material Group Segment (P)	=		

**Report Output:**

Source System	Contract / Scheduling Agreement	Change Number	Old Price in Contract in Ord PU	New Price in Contract in Ord PU	Delta % (New - Old) Price in Contract in Ord
WP1 Client 400	4600000530	395268799	1,364.06	1,949.70	42.9335
		395604062	49,404.53	161,512.28	226.9179
		395604160	161,512.28	49,404.53	-69.4112
		397540129	24,007.50	28,897.13	20.3670
	4600000860	396377965	4,674,660.52	2,868,519.72	-38.6368
	4600000862	395588810	270,193.50	55,422.86	-79.4877
		396018297	16,705.39	24,603.34	47.2778
		396396192	90,966.60	242,475.09	166.5539
		397533678	21,260.37	30,795.08	44.8473
	4600001141	394443430	855.00	1,004.00	17.4269
		394443528	855.00	1,004.00	17.4269
		397606124	1,004.00	1,004.00	0.0000
		397606179	1,004.00	1,004.00	0.0000
	4600001152	396766572	299.58	296.31	-1.0915
	4600001153	396764028	297.32	292.29	-1.6917
	4600001154	396766566	257.56	252.53	-1.9529
	4600001170	396983219	56,398.14	57,630.58	2.1852
	4600001216	396978819	1,089,541.42	1,237,928.39	13.6192
	4600001251	396766642	264.08	258.81	-1.9956
	4600001261	396865568	664.50	666.20	0.2558
		396865593	772.85	685.00	-11.3670
	4600001262	396865522	719.00	738.60	2.7260

**Exception:**

Delta % (Old - New) Unit Price in Contract in BUoM
42.9335953
226.9179567
-69.4112856
20.3670936
-38.6368335
-79.4877153
47.2778546
166.5539770
44.8473380
17.4269006
17.4269006
0.0000000
0.0000000
-1.0915281
-1.6917799
-1.9529430
2.1852494
13.6192133
-1.9956074

Main functionalities

Broadcast

Maintenance

Known bugs

Recurring procedure

Planned Evolution