

# Manufacturing Costs

- General presentation
    - Objective of the application
    - Usage information
    - History
  - Roles & Access
    - Roles and access
    - Authorization variables
  - Dataflow overview
    - BOM data flow
      - WP1 flow
      - PF1 flow
      - BOM overall dataflow
    - Raw Material Forecast Integration (Noveware)
    - "Buy & Sell" products (Noveware)
    - "Make or Buy" products (SpP)
    - BOM Reloading
  - Functional and Technical rules on Workbench + Reporting
  - Rules & Explanations
  - Dependencies with other applications
- Data loadings
  - Info providers and objects loaded
  - Loading frequency
  - Average performance
  - Record Keeping
- Reporting
  - Main queries
  - Main functionalities
  - Global properties
  - Variables
    - Definitions
    - Variable Sequence
  - Filters
  - Key figures
  - Characteristics
  - Broadcast

## General presentation

### Objective of the application

Manufacturing VC query (**QV\_BW\_QRY\_CPCOPC04\_0001**) brings the Variable Cost (**VC**) of a product (sum of Raw Materials + Packaging + Tolling + Utilities costs).

We bring these detailed costs from SAP from the BOM (Bill of Material).

The BOM brings, for a given Finished Product/Plant/Month, the detailed list of components with the corresponding quantities and costs.

In the query, we calculate the **FL Variable Cost** for projected months, using the forecasted prices for Raw Material and Energy (input by the users in IP workbooks). If no forecast is found, then we extrapolate last Actual price to the future months.

Tool Leader + IT leader of the application:

### Usage information

### History

## Roles & Access

### Roles and access

List of application role + menu role and explanation if we have several applications role with specials rules.

Role Code	Role Description	Explanation
ZR_RCS_CA_M83	Forward Looking ICM - Manufacturing	Role Menu
ZBI_RCS_CO_A09	Forward Looking ICM - Manufacturing	Authorization objects

## Authorization variables

List of authorization variables mandatory for the application.

Authorization variables	Object
V_CPFCTR1_2_0006	CPFCTR1_2
V_C_PLANT_0012	C_PLANT
V_C_AUTHMA_0001	C_PLANT__C_AUTHMA

## Dataflow overview

Composite Provider CPCOPC04 (FL ICM - Manufacturing Unit Cost) contains 2 DSOs:

- ABCOPC06 - WP1
- ABCOP06B - PF1

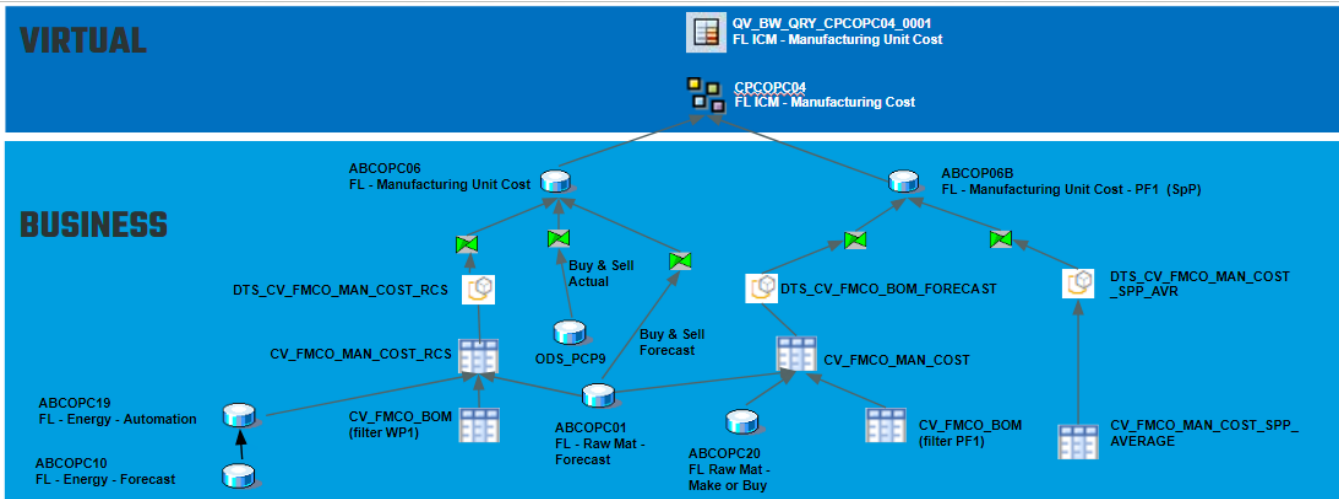

The BOM data from both ERPs is harmonized in **CV\_FMCO\_BOM** to be consumed by the Manufacturing Cost CVs.

## BOM data flow

First step to calculate Manufacturing Cost is to load the BOM.

### WP1 flow

2 datasources are used to define the BOM scope

- DTS\_PU\_RM01: to get from P&L (MVCOPA01) all materials sold in the past 24 months
- ABCOPC07: to get materials with Sales Forecast (eventually new materials with Sales Forecast but no actual sales yet)

Then, in the Transformations, for each plant/finished material, we call table function ZCDS\_BOM\_ALL, which is implemented with method GET\_BOM\_ALL (class ZCL\_BOM\_ALL).

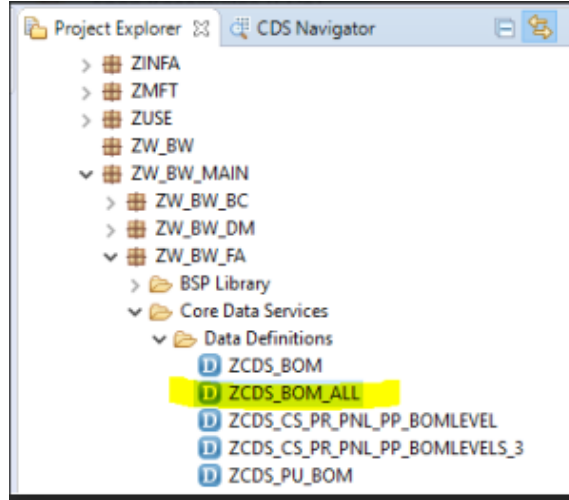
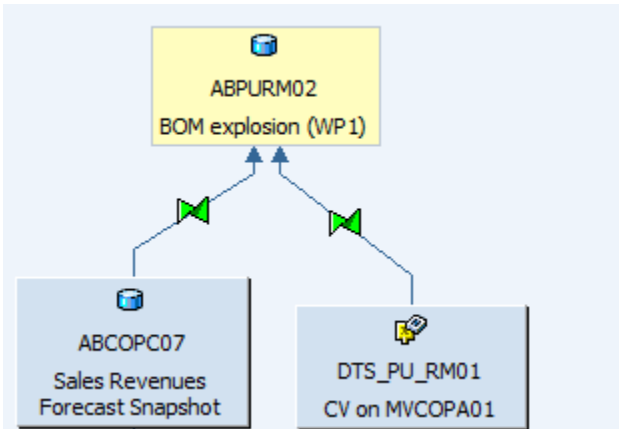

This method GET\_BOM\_ALL does the BOM explosion via lookup in ODS\_PCP1 with a recursive logic.

Each subsequent level is built by taking the component and reading again ODS\_PCP1 using the component as "father", to check if it explodes further (if it's an intermediate product).

For example: when building level 2, the component (COMPNT) of level 1 is used as material (MATNR) of level 2 and so on up to level 10.

```

IF x = 2 THEN
  level2 = SELECT a."PLANT", A."/BIC/C_MATNR" as C_MATNR, A."/BIC/C_COMPNT",A."FISCPER",A."/BIC/C_COSTIYP",
    a."ACTIYPE", SUM (a."OI_MENGE")/COUNT(distinct(b."C_MATNR")) as "OI_MENGE", AVG (A."LOTSIZE_IT") as "LOTSIZE_IT",A."BASE_UOM",A."UNIT",A."WORKCENTER", :X as "LEVEL",
    a.co_area, A.COSTCOMP, A.COMPESTRUC
  from "/BIC/AODS_ECP100" A INNER JOIN :BOM_LEVEL1 B
  on a."/BIC/C_MATNR" = B."/BIC/C_COMPNT"
  where a."FISCPER" = B."FISCPER" AND
    a."PLANT" = B."PLANT" AND

```

After the explosion of the BOM, the calculated quantity of each component in each level is stored in ABPURM02 in field K\_MENGECK.

Then ABPURM02 is used in CV\_ALL\_BOMLEVELS\_N2 where we calculate the cost, getting Raw Material prices from ODS\_PCP3 and Utilities prices from ODS\_PCP8.

Then CV\_ALL\_BOMLEVELS\_N1 is on top of CV\_ALL\_BOMLEVELS\_N2 just for currency conversion purposes.

### PF1 flow

Data is loaded from table ZCO\_PRICE\_RM in PF1 (this table is generated with program ZCO\_PRICE\_SIMULATION in PF1).

The logic of the BOM explosion resides in PF1 and it goes straight-forward to BW.

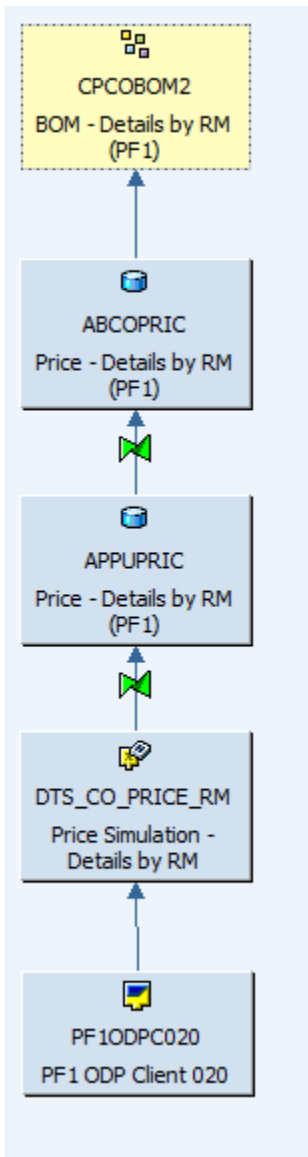

Then calculation view CV\_FMCO\_BOM joins BOM data from both ERP

PF1 - from CPCOBOM2

WP1 - from ABCOCP05

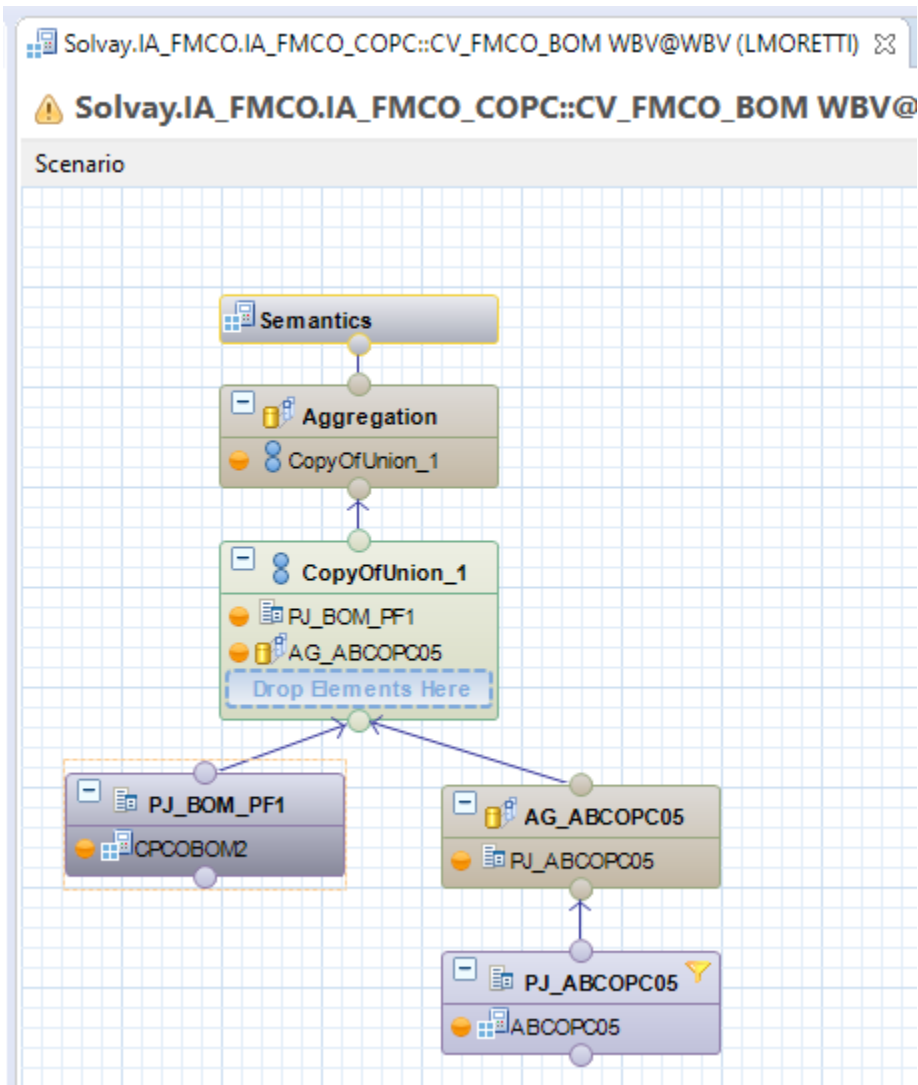

ABCOPC05 is an intermediate DSO (used only for WP1 data) for the correct aggregation of data (exception aggregation on price KF) as we remove some characteristics (level and intermediate product) to send to Manufacturing Cost CV.

**BOM overall dataflow**

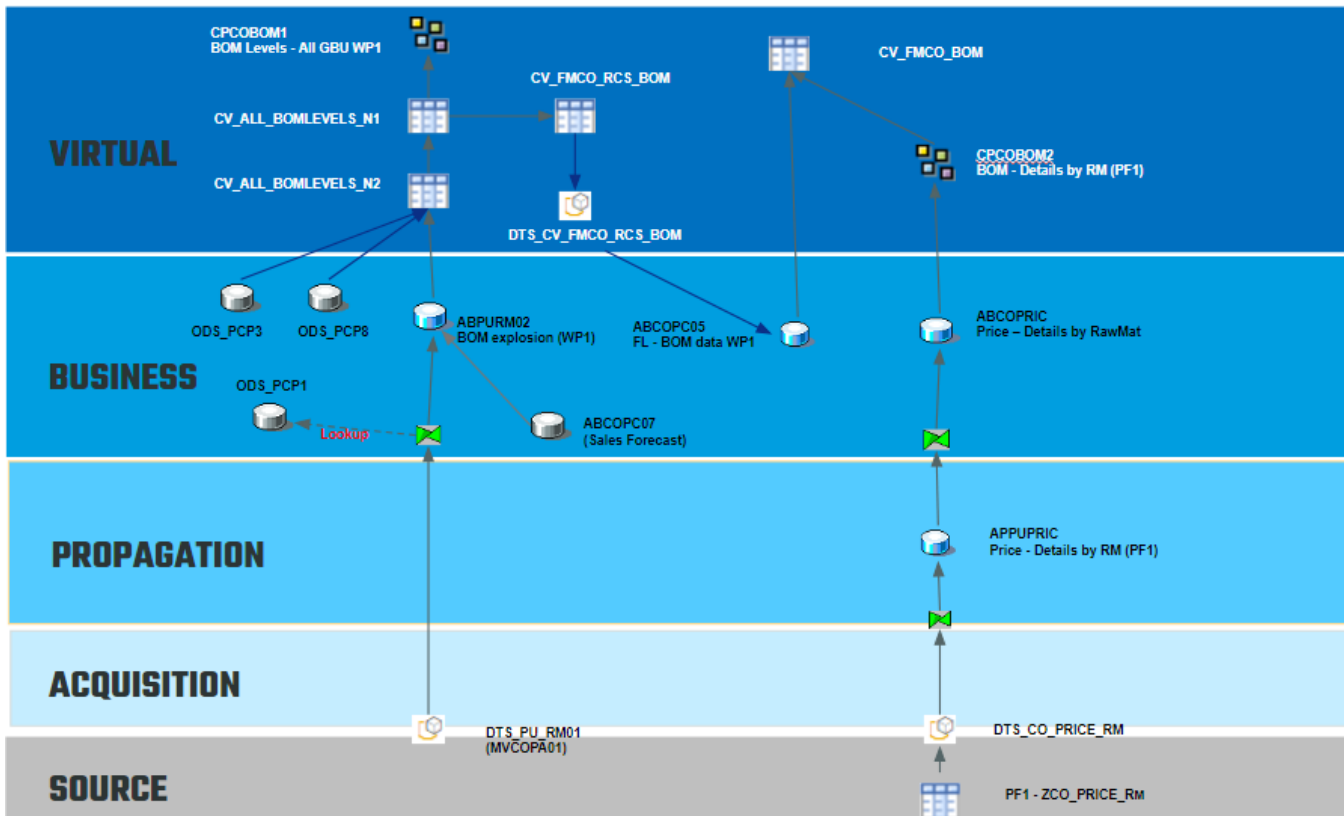

There are 2 different BOM queries (not used directly in Pricing dashboard, but can be used to check the BOM data with all the available granularity)

- QV\_BW\_QRY\_CPCOBOM1\_0001 - for WP1
- QV\_BW\_QRY\_CPCOBOM2\_0001 - for PF1

You can find the dimensions of each query here:

### Granularity of the BOM

From WP1, each record in the BOM is an individual component, which is **either** a Raw Material (C\_BOMCPT) **or** an Activity Type (OACTTYPE).

From PF1, we don't have the same granularity. **Only the critical raw materials are detailed** (with quantity and price). This is what we call "Simple" version (**VERSION = 'S'**).

Then we have some "buckets" that aggregate the costs as follows:

- OTHER\_RM - Sum of the costs of the non-critical raw materials
- OTHER\_PK - Sum of the cost of Packaging Materials
- OTHER\_UTI - Sum of the cost of Utilities
- OTHER\_TOLL - Sum of the cost of Tolling

### Raw Material Forecast Integration (Novecare)

DSO ABCOPC01 stores Raw Material forecast prices (saved by the users in the workbook).

Field K\_AMT\_EUR is the final confirmed price (in EUR/1000 KG), used to integrate in Manuf. query

This DSO is integrated in CV\_FMCO\_MAN\_COST\_RCS with the following logic:

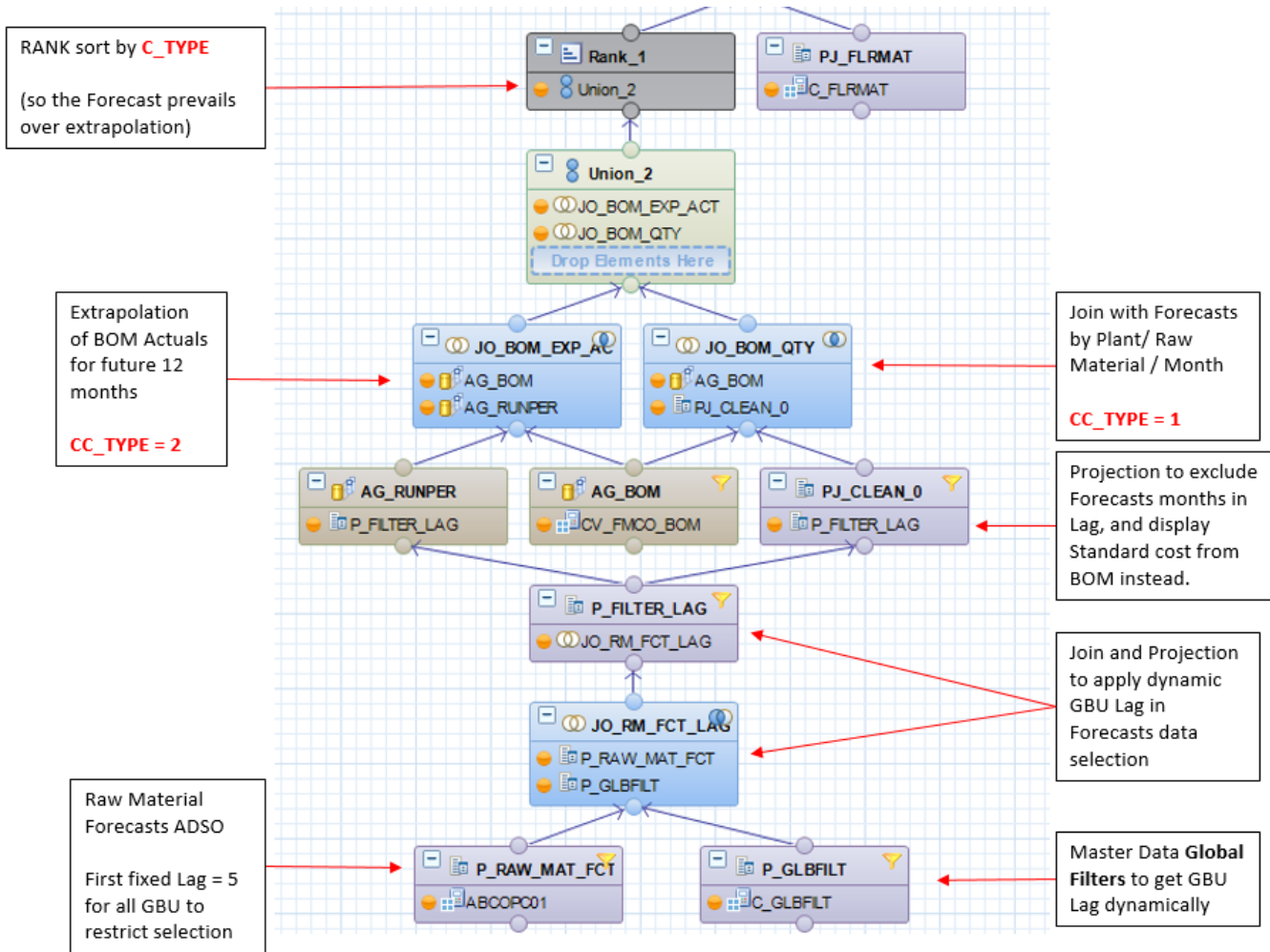

A dynamic month lag is applied by GBU, which is stored as a parameter LAG\_xx (xx = GBU) in the Global Filter Master Data C\_GLBFLT. If no lag is set in the Master Data, the default one is 1 month applied to the relevant GBU. The Forecast months included in this lag period are excluded, and then the Standard cost is displayed instead during this lag.

CC\_TYPE = 1 (Forecast) ==> Value Component 009 (Raw Material Forecast)

CC\_TYPE = 2 (Actual) ==> Value Component 004 (Raw Material Actual)

### "Buy & Sell" products (Novicare)

These are products that the GBU buy and re-sell, and **they have no BOM in SAP.**

They are identified in Critical Raw Material Master Data C\_FLRMAT, with "Critical flag" (C\_FLRMATF) = "B" (No BOM)

We create a "virtual" BOM in BW assigning the same material code as both Finished Product and Raw Material, with the whole quantity of the lot size (1000 KG).

This is done with 2 different Transformations into ABCOPC06 (WP1 only):

▶ TRSF: ABCOPC01 -> ABCOPC06

▶ TRSF: ODS\_PCP9 -> ABCOPC06

- [TRSF: ABCOPC01 -> ABCOPC06](#)

Here we get from ABCOPC01 the forecast prices for Buy & Sell products.

- [TRSF: ODS\\_PCP9 -> ABCOPC06](#)

Here we get the actual price from P&L. query QVSBS\_QRY\_MVCOPA06\_0001 (technically we take data directly from ODS\_PCP9 field C\_MVR\_CP).

We adjust the price to a lot size of 1000 KG and also convert the price to EUR using CAR3 exchange rate.

Also in this transformation, we extrapolate Actual price for the future 12 months, in case no forecast exists in ABCOPC01.

## "Make or Buy" products (SpP)

The relevant raw materials for "Make or Buy" process are marked in Critical Raw Material Master Data **C\_FLRMAT**, with "Critical flag" (C\_FLRMATF) = "I" for internal and "E" for external.

In ABCOPC20 we find the Usage Factor (K\_USGFACT) to replace the quantity from the BOM.

This Usage Factor is filled in the corresponding workbook by Material Group / Finished Material / Raw Material / Quarter.

In CV\_FMCO\_MAN\_COST we read data from ABCOPC20 joining with CALMONTH to extrapolate the months in each quarter and copy the Usage Factor.

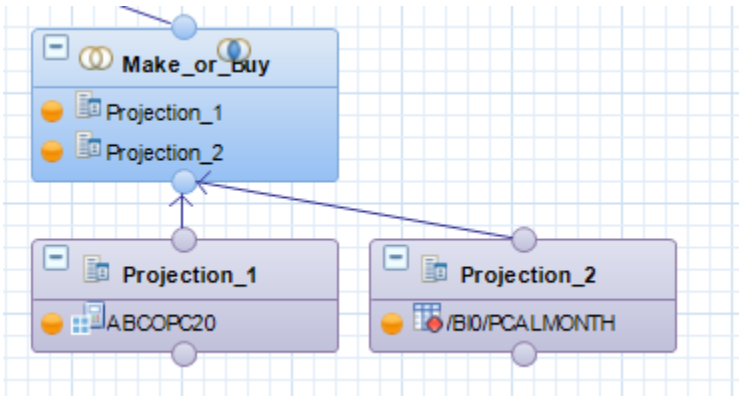

$$CC\_MORB\_QTY = K\_USGFACT * 1000$$

$$CC\_MORB\_AMOUNT = CC\_MORB\_QTY * \text{Forecast Price}$$

Then in [TRSF: DTS\\_CV\\_FMCO\\_BOM\\_FORECAST -> ABCOP06B](#) we take the "Make or Buy cost" if it exists.

The Usage Factor can be seen in Manufacturing query but it's hidden by default.

## BOM Reloading

In case of any period reloading, a Global Parameter is set in C\_GLBFLT to condition the code in the relevant Transformations :

TRSF: DTS\_CV\_FMCO\_BOM\_FORECAST WBD\_HANAIV -> ABCOP06B

TRSF: DTS\_CV\_FMCO\_MAN\_COST\_RCS WBD\_HANAIV -> ADSO ABCOPC06

TRSF: ODS\_PCP9 -> ABCOPC06

TRSF: DTS\_CV\_FMCO\_BOM\_FORECAST WBD\_HANAIV -> ABCOP06

The RULE = 'BOM\_RELOAD' allows to change the loading logic in these Transformations, to keep only Actuals in case of period reloading.

Field C\_LOW must be changed to 'Y' in case of reloading.

## Table: /BIC/PC\_GLBFLT

EX	/BIC/C_STREA...	/BIC/C_RULE	/BIC/C_GLBFLT	OBJVERS	CHANGED	/BIC/C_DESC	/BIC/C_SIGN	/BIC/C_OPTION	/BIC/C_LOW	/BIC/C_HIGH	/BIC/C_ACTIVE
	PRICING	BOM_RELOAD	001 A				I	EQ	N		Y

You can find FL-ICM overall architecture here:

## Functional and Technical rules on Workbench + Reporting Rules & Explanations

Novecare (in WP1) works with Standard Cost.

Beginning of month **M**, we have the cost for month **M**.

Specialty Polymers (in PF1) works with Actual Cost.

Beginning of month **M**, we have the cost for month **M-1** (last closed month).

In order to have a common view, for a unique Running Period, this is the way we generate data in Manufacturing Cost query.

LOGSYS	RUNPER	CALMONTH	VALUE COMPONENT	Comments
WP1	Mar-22	Mar-22	4 (RM Actual)	Standard Cost
		Apr-22	9 (RM Forecast)	RM Unit Price Forecast from 03/2022
		May-22	9 (RM Forecast)	RM Unit Price Forecast from 04/2022
		Jun-22	9 (RM Forecast)	RM Unit Price Forecast from 05/2022
LOGSYS	RUNPER	CALMONTH	VALUE COMPONENT	Comments
PF1	Mar-22	Feb-22	4 (RM Actual)	Actual Cost
		Mar-22	9 (RM Forecast)	RM Unit Price Forecast from 03/2022
		Apr-22	9 (RM Forecast)	RM Unit Price Forecast from 04/2022
		May-22	9 (RM Forecast)	RM Unit Price Forecast from 05/2022

Note that for Novecare (WP1), there is a month lag in the RM Forecast price for the projected months (for example, April Forecast is calculated with the price from March).

2 different calculation views were created as we can only filter a single period to read BOM data, so in each CV, Run Period is calculated differently:

### CV\_FMCO\_MAN\_COST\_RCS (WP1)

RUNPER is equal to FISCPER from DTP (used to extract BOM)

### CV\_FMCO\_MAN\_COST (PF1)

RUNPER = FISCPER from DTP +1

Dependencies with other applications

Data loadings

Info providers and objects loaded

Process chain **PC\_COPC\_10** scheduled monthly on the 6th at 03:00 AM CET // **BOM loadings constraints to consider before changing scheduling**  
Loading frequency //

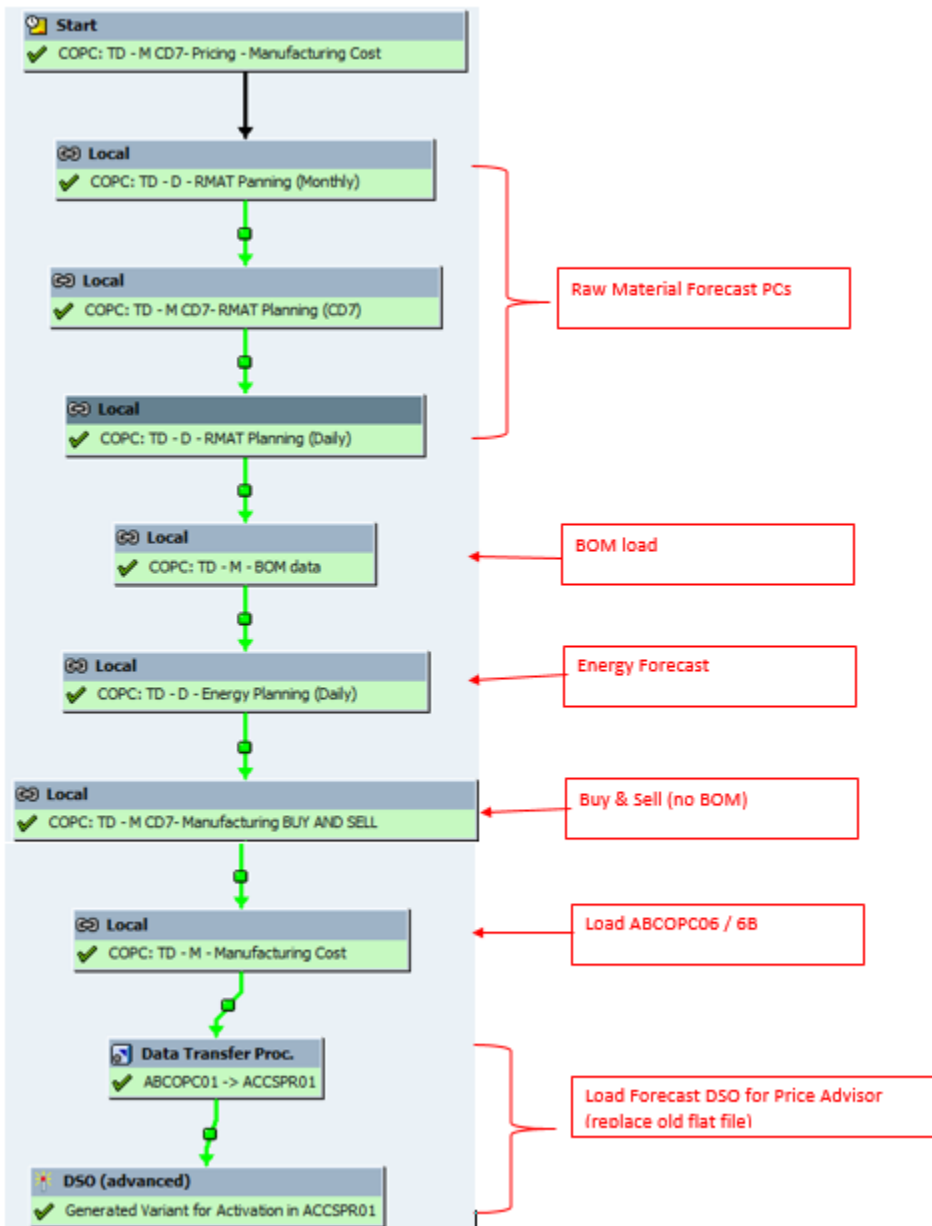

Process chain **PC\_COPC\_20** scheduled monthly from the 7th to 14th at 03:00 AM CET No BOM loading No scheduling impact

This process chain reloads Manufacturing Cost into ABCOPC06 to take into account potential changes in the forecast prices done by the users in the workbooks.

It is not necessary to reload the BOM from SAP, since there are no changes after the costs are released in WP1.

It contains a step (with an ABAP program) to delete from ABCOPC06 the requests from the same Run Period before reloading, to avoid duplication.

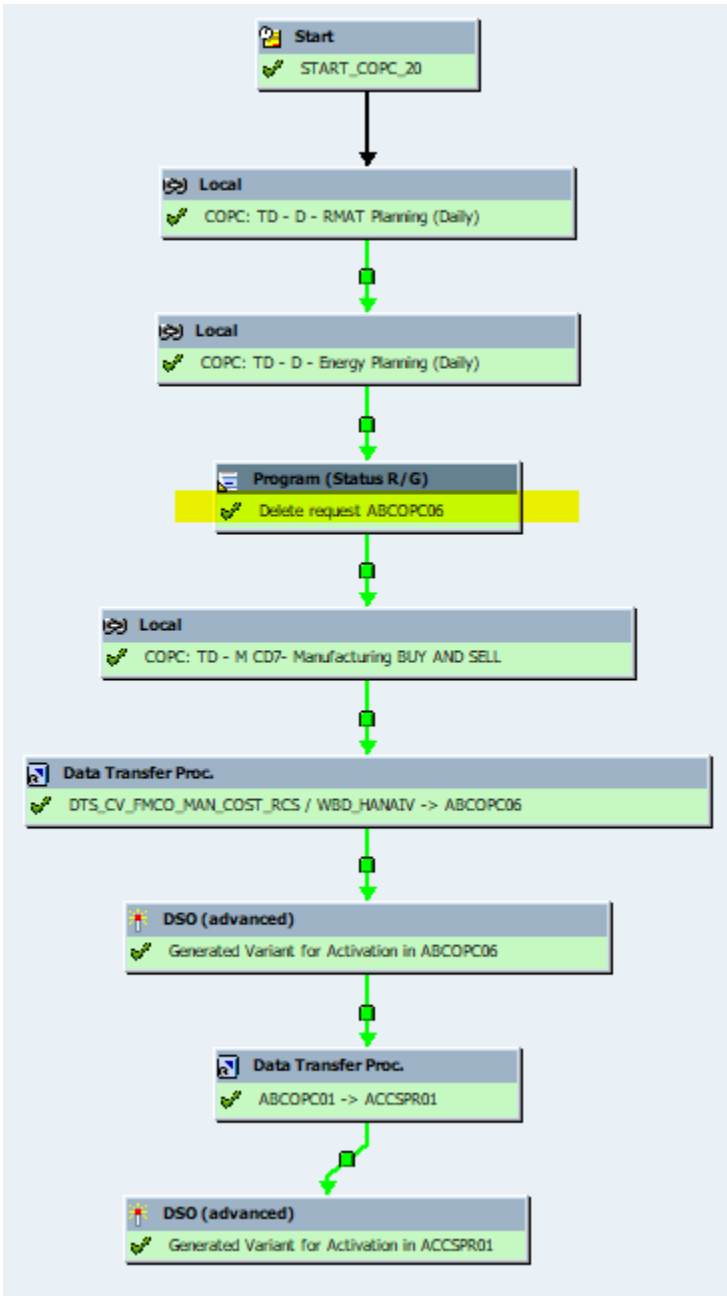

## Loading frequency

**/\ Dependencies to consider before changing PC scheduling /\**

We need all the below objects to be properly loaded at the time of the FLICM Manufacturing loading process.

**ABCOPC07** Sales Revenues Forecast Snapshot  
**MVCOPA01** Profitability Analysis: COPA - P&L -> 25 Infoproviders  
**ODS\_PCP1** CCR: Product Cost Items  
**ODS\_PCP3** CCR: released costs estimates  
**ODS\_PCP8** Resource's Unit Price

The FLICM Manufacturing process is first dealing with the loading of **ABPURM02** BOM explosion (WP1), using all dependent objects above. The loading time restrictions for each are as follow :

**MVCOPA01** Profitability Analysis: COPA - P&L -> 25 Infoproviders  
**PC\_COPA\_PL\_GLOBAL** COPA: PL Global Process Chain - **Daily 1:00 AM**

**ODS\_PCP1** - CCR: Product Cost Items  
 DTP: DTS\_KEKO\_CKIS (WP1) -> ODS\_PCP1 - Delta  
**RSP\_COPCP\_MONTHLY** Integ Margin : **2 workdays from start of month (FR calendar) - 11:30 PM**  
**RSP\_PVELOCITY** PVelocity : **3 workdays from start of month (BE calendar) - 10:00 AM**  
 DTP: ABDSOPCP1 -> ODS\_PCP1 - PC\_FILE - full  
**PC\_INT\_MARGIN** Integ Margin : **3 days from start of month (no Sunday) - 00:30 AM**

**ABCOPC07** - Sales Forecasts  
**PC\_COPC\_16** COPC: TD - M - Sales Loadings : **Daily 3:00 AM + 03:00 PM - not on Sundays nor bank holidays**

**ODS\_PCP3** CCR: released costs estimates  
**RPC\_CCR\_PCP1\_MTHLY\_CHAIN** CCR Monthly Process Chain : **1 workday from start of month (FR calendar) - 11:30 PM**

**ODS\_PCP8** Resource's Unit Price  
**RSP\_COPCP\_MONTHLY** Integ Margin : **2 workdays from start of month (FR calendar) - 11:30 PM**  
**RSP\_PVELOCITY** PVelocity : **3 workdays from start of month (BE calendar) - 10:00 AM**

We must take the worst restriction above as the time to consider before starting the FLICM Manufacturing loading process.

If we consider the second monthly Delta loading of ODS\_PCP1, it is **3 workdays from the start of month (BE calendar) - 10:00 AM**. This object is the BOM structure used to explode each Material with recursive logic (WP1 source : ZBW\_KEKO\_CKIS (Extraction of cost items)).

**Therefore, if the 1st day of the month is a public holiday on Friday (New Year's Day or All Saints' Day in FR or BE calendar), the worst time of BOM loading will be the 6th at 10:00 AM.**  
**We can optimize the FLICM Manufacturing loading on the same day at 10:00 PM**

If we consider the first monthly Delta loading of ODS\_PCP1, it is **2 workdays from start of month (FR calendar) - 11:30 PM**

**If the 1st day of the month is a public holiday on Friday (New Year's Day or All Saints' Day in FR or BE calendar), the worst time of BOM loading will be the 5th at 11:30 PM.**  
**We could schedule the FLICM Manufacturing loading on the next day the 6th at 03:00 AM.**

## Average performance

Key Figure	Estimation
~ Average Process Chain Runtime	
~ Average nb of rows loaded per load	
~ Total nb of rows loaded (if full)	
~ Average Runtime for 10k lines	

## Record Keeping

## Reporting

### Main queries

Manufacturing Unit Cost query : **QV\_BW\_QRY\_CPCOPC04\_0001**

### Main functionalities

It combines BOM (Bill of Material) data for Actuals + Raw Material Forecast.

## Global properties

**General: QV\_BW\_QRY\_CPCOPC04\_0001 - FL ICM - Manufacturing Unit Cost** Active View

---

**General**

Technical Name: QV\_BW\_QRY\_CPCOPC04\_0001

Description:

InfoProvider: CPCOPC04

Key Date:

---

**Output Settings**

Adjust Formatting after Refreshing

Suppress Repeated Key Values

Show Scaling for Measures

Sign Format:

Zero Format:

Custom Zero Format:

**Result Location**

Rows:  Above  Below

Columns:  Left  Right

---

**Remote Access**

By Easy Query

By OLE DB for OLAP

By OData

External SAP HANA View

**Zero Suppression**

Applies to:  Rows  Columns

Condition:

---

**Universal Display Hierarchy**

Active on rows

Expand to Level:

Active on columns

Expand to Level:

## Variables

### Definitions

Variable Name	Info-object	Selection Type	Required	Description/Explanation
0I_CALMO	0CALMONTH	Interval	No	Calendar Year/Month
V_C_PLANT_0012	C_PLANT	Authorization with Input	No	Plant
V_CPFCTR1_2_0006	CPFCTR1_2	Authorization with Input	No	Global business Unit
V_C_MATNR2_0001	C_MATNR2	Select Option	No	Raw Material
V_C_AUTHMA_0001	C_AUTHMA	Authorization	No	Authorization Scope
V_0CALMONTH_0062	C_RUNPER	Interval	No	Run Period

### Variable Sequence

### Filters

### Filter: Fixed Values

- ▼ [C\_PLANT] Plant
  - [V\_C\_PLANT\_0012] Plant (Authorization with input select option)
- ▼ [C\_MATNR2] Material
  - [V\_C\_MATNR2\_0001] Material (Select option, Optional)
- ▼ [C\_RUNPER] Run Period
  - [V\_0CALMONTH\_0062] Running Period
- ▼ [CPFCTR1\_2] GBU
  - [V\_CPFCTR1\_2\_0006] GBU (Select Optional, Optional, Auth)
- ▼ [C\_PLANT\_C\_AUTHMA] Authorization Scope
  - [V\_C\_AUTHMA\_0001] Authorization Scope (Authorization, No input)
- ▼ [0CALMONTH] Calendar Year/Month
  - [0I\_CALMO] Calendar Month/Year (Interval, Optional)

### Key figures

#### Columns

- ▼ Key Figures
  - [CC\_AMOUNT] FL ICM - SPP Energy Average (last 3 Months)
  - [K\_ADJPRI] Adjusted Price
  - [BW\_CKF\_CPCOPC04\_0001] Component Unit Price (EUR/TO)
  - [BW\_CKF\_CPCOPC04\_0002] Product Cost (EUR/Lot Size KG)
  - [BW\_CKF\_CPCOPC04\_0003] Product Lot Size
  - [BW\_CKF\_CPCOPC04\_0004] Component Quantity
  - [BW\_CKF\_CPCOPC04\_0005] Component Quantity (float)

### Characteristics

**Rows**

- [0LOGSYS] Source System
- [C\_RUNPER] Run Period
- [0CALMONTH] Calendar Year/Month
- [CPFCTR1\_2] GBU
- [C\_PLANT] Plant
- [C\_MATNR2] Material
- ▼ [C\_RWPLT2] BOM Component Plant
  - [C\_ZONE] BFC Geographie/Zone
- ▼ [C\_BOMCPT] BOM Component
  - [C\_PURPROD] Product (PUR)
  - [C\_PRODGRP] Value Chain (PUR)
- [C\_ZZWWE41] Origin Plant
- [C\_VALCOMP] Value Component
- [C\_FLRMATF] FL Raw Material Critical Flag
- [C\_ERNAM] Buyer Name
- [C\_AENAM] Buyer who changed value
- [C\_FLRMATC] FL Raw Mat Classification

**Free**

- [\$] [0BASE\_UOM] Base Unit of Measure
- [0COSTCOMP] Cost Component
- [0CO\_AREA] Controlling area
- [0CCOMPSTRUC] Cost Component Structure
- [0ACTYPE] Activity Type
- [\$] [0CURRENCY] Currency
- [\$] [0UNIT] Unit (lot size)
- [\$] [C\_BSUOM1] Unit Of Measure (float)
- [C\_FLAGM] FL ICM - Flag Material by Plant (Mono/Multi)

Broadcast