

Technical Documentation - Controlling Production costs report (decommissioned)



This application was decommissioned and replaced by IMEP. Data is used only for historical data from queries and not possible in IMEP because there is no GBU linked to them.

- [1 Access Management](#)
- [2 DataFlow](#)
 - [2.1 Overview](#)
 - [2.2 Technical Rules on Workbench](#)
 - [2.3 Dependencies with other applications](#)
- [3 Data Loading](#)
 - [3.1 Link with CPX system:](#)
- [4 Data Quality Control](#)
- [5 Operational Documentation](#)
 - [5.1 Procedures](#)
 - [5.2 Scheduling](#)
 - [5.3 Monitoring](#)
 - [5.4 Error Handling](#)
 - [5.5 Known Bugs](#)
 - [5.6 Roadmap](#)

Access Management

Roles & Access

List of application role + menu role and explanation if we have several applications role with specials rules.

Role Code	Role Description	Explanation

Authorization Objects

List of authorization objects mandatory for the application.

Authorization object	Explanation

DataFlow

Overview

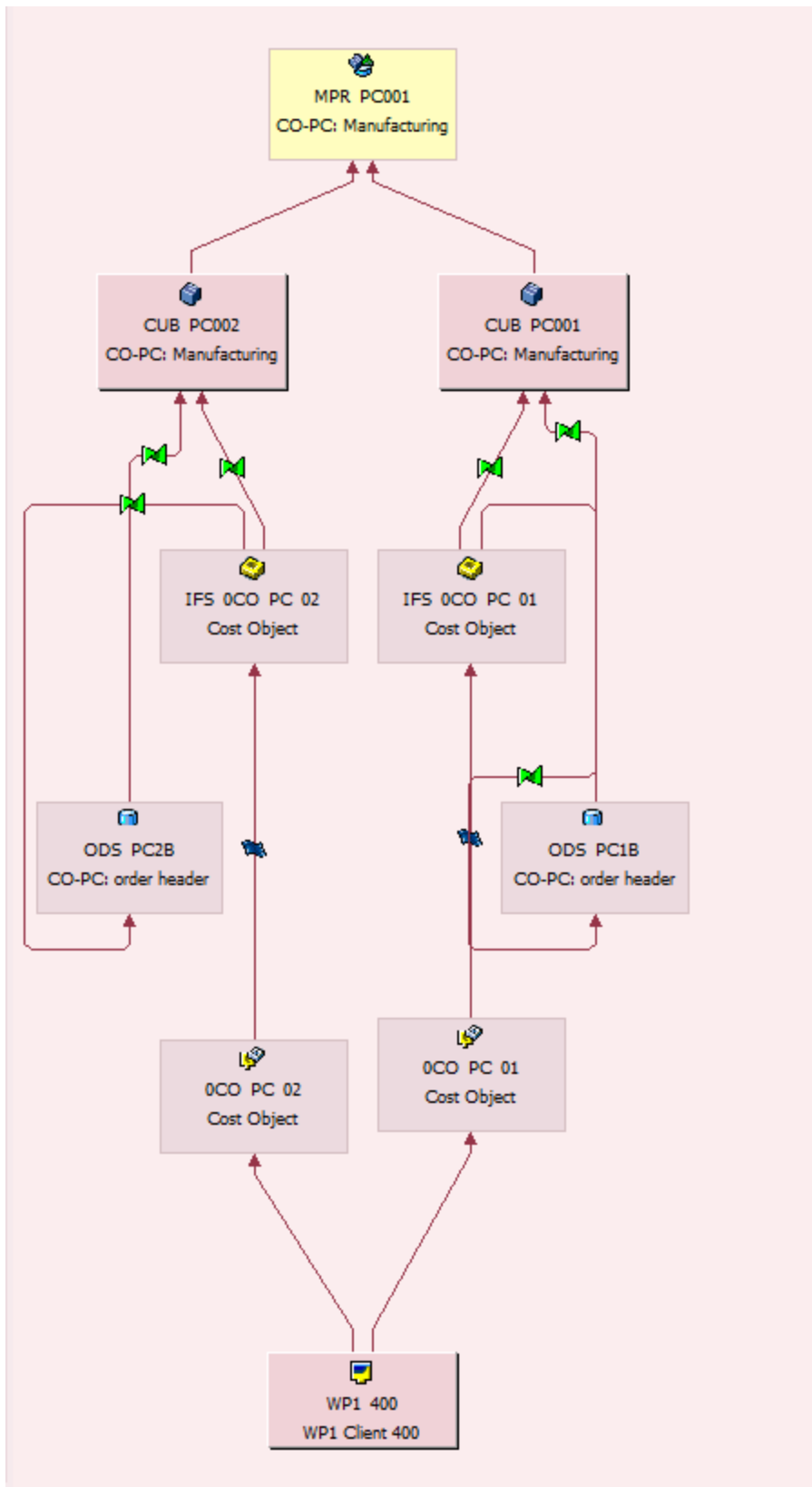

Technical Rules on Workbench

Objective of the application: [general documentation about C OPC](#)

Dependencies with other applications

We should have the information where the application is sending or receiving information (e.g. APD open hub)

Data Loading

About the monthly process chain : RSP_COPC_MONTHLY

The process chain is scheduled with an event : Z EVT_PC_RSP_COPC_MONTHLY

This event is launched by the daily process chain : RSP_DAILY

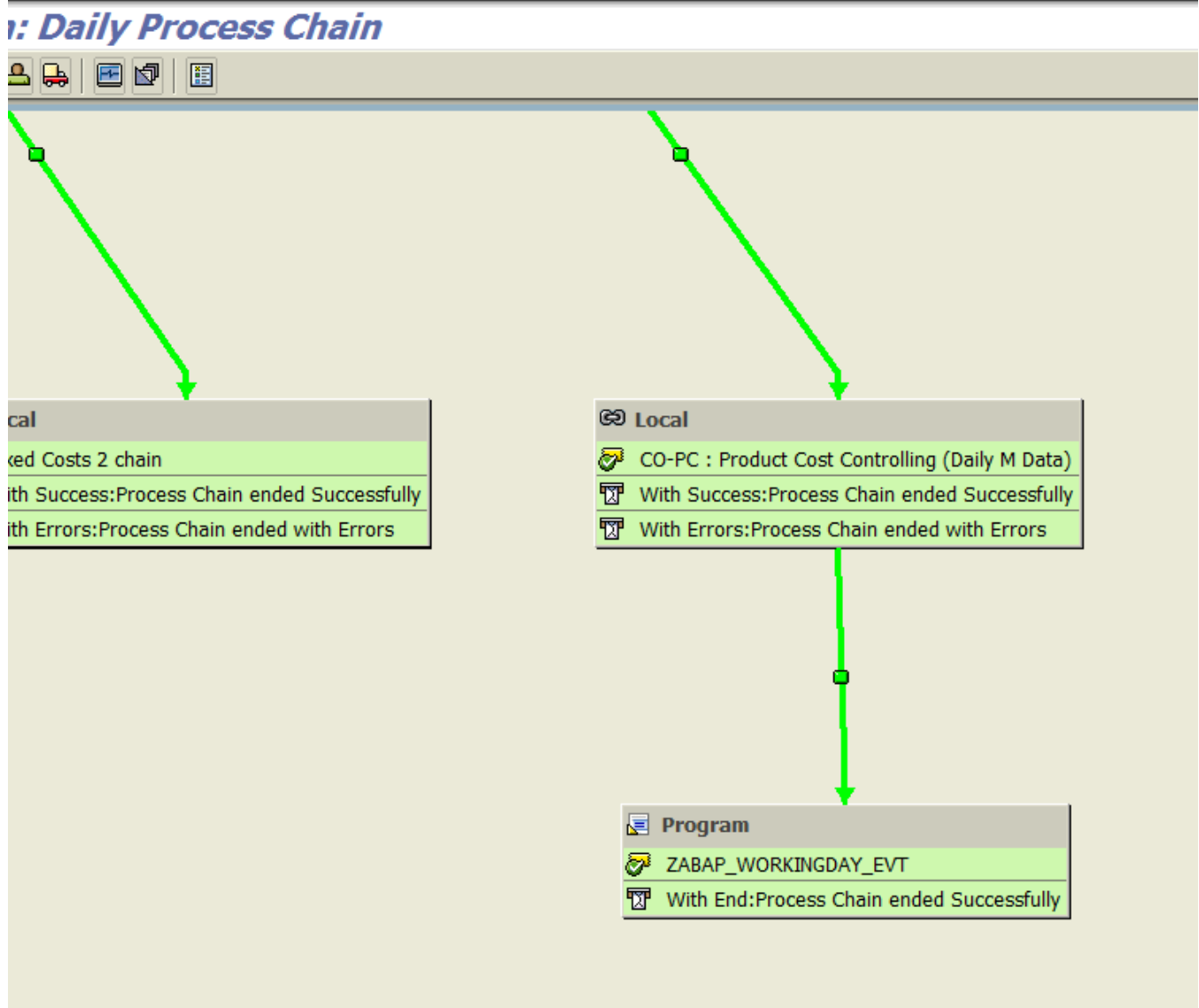

The variant ABAP_WORKING_DAY is done with the program Z_WORKINGDAY_EVT + Variant ZPP_PC_CCR

Data Browser: Table RSPCVARIANT: 8 of 8 Hits

TYPE	VARIANTE	OBJVE...	LNR	FNAM	SIGN	OP...	LOW	HIGH
ABAP	ZABAP_WORKINGDAY_EVT	A	1	DESTINATION	I	EQ		
ABAP	ZABAP_WORKINGDAY_EVT	A	2	EVENT	I	EQ		
ABAP	ZABAP_WORKINGDAY_EVT	A	3	PARAM	I	EQ		
ABAP	ZABAP_WORKINGDAY_EVT	A	4	PROGRAM	I	EQ	Z_WORKINGDAY_EVT	
ABAP	ZABAP_WORKINGDAY_EVT	A	5	VARIANT	I	EQ	ZPP_PC_CCR	
ABAP	ZABAP_WORKINGDAY_EVT	A	6	X_LOCAL	I	EQ	X	
ABAP	ZABAP_WORKINGDAY_EVT	A	7	X_PROGRAM	I	EQ	X	
ABAP	ZABAP_WORKINGDAY_EVT	A	8	X_SYNCHRON	I	EQ	X	

ABAP: Variants - Initial Screen

Program: Z_WORKINGDAY_EVT
 Variant: ZPP_PC_CCR

Subobjects
 Values
 Attributes

Now the variant is customized to run the process chain from 1st to 5th working day before only the 5th working day to be sure to retrieve from the ECC part all informations from the previous month (month n-1).

Edit Variants: Variant ZPP_PC_CCR

Variant Attributes

Flag how workday be calculated	+
Date the beginning	01.03.2017
Date the end	06.03.2017
Factory calendar ID	50
Nb workingday subordinate	1
Nb workingday upper	5
ID Event	ZEVT_PC_RSP_COPC_MONTHLY
Optional Event Parameters	
Instance of the Event	wbpsapr3

Link with CPX system:

In scope of 8612 - Solstice Aro project, a link with CPX system was done to calcul and use vault informations in integrated margin.

Data Quality Control

Data come from SAP system. To compare data between BW and sources systems, check propagation layers.

Operational Documentation

Procedures

<Describe the recurring procedures needed to operate the application (eg. start/pause/terminate/restart the app processes, data preparation, data ingestion, ETL, data visualization, data export, other manual activities)>

Scheduling

<Describe the scheduling in place for the application (eg. existing jobs, trigger time/event based, dependencies)>

Monitoring

<Describe the monitoring checks to confirm the application is performing well (eg. check the overall status, check performance metrics like runtime /data volume/memory/disk/CPU, maintain and react to alerts/notifications)>

Error Handling

<Describe how to handle errors (eg. error codes, description and respective resolution, alert users)>

Known Bugs

<List the existing bugs, its criticity, workarounds and resolution plan.>

Roadmap

<List past & future evolutions for the application (including links to MED/FSD/TSD)>