



ERP-300 Workflow for FI-AR Sundry Invoices

Approved

Status	Approved
Owner	Alexander Bechter
Stakeholders	GONZALVEZ-ext, Antonio CHANE WON IN-ext, ivan
Jira Request ID	 ERP-117 - Jira project doesn't exist or you don't have permission to view it.
Jira Development ID	 ERP-300 - Jira project doesn't exist or you don't have permission to view it.

High- Level Specification

Parameter	Value
Application System	S/4 HANA (all systems)
Business Process Reference	09.05.02.02. Post Sundry Debtor Invoices/Credit Memos

Functional Overview

As part of the SyWay program, it was decided to re-introduce an FI-AR invoicing process for exceptional (sundry) customer invoicing scenarios where the use of the regular sales processes via the Sales and Distribution (SD) module is not feasible/practical due to master data, process design constraints and/or specific accounting requirements. To bypass the complexities and system dependencies in terms of configuration and master data setup, the FI-AR sundry invoicing process is meant for non-recurring or urgent sales scenarios only that can't be managed adequately in the upstream Sales and Distribution module. To safeguard that the process is only used in exception scenarios, various controls are implemented. One of the endorsed controls is a park/post workflow approval process to ensure that all sundry customer invoices posted via the direct FI-AR route are validated by authorized reviewers and approvers.

Scope and Objectives

The park and post approval process will use customized workflow templates to enable the electronic flow of initially parked documents through to the appropriate reviewers and approvers and in countries with e-invoicing requirements also the connectivity and integration with the e-invoicing solution implemented as part of the SyWay program.

This document explains the triggers, start conditions, routing as well as processing requirements for the park/post approval workflow implemented in the sundry customer invoicing process in S/4 HANA.

Assumptions

- Approvers are required to log on to the respective S/4HANA systems to complete the approvals via Fiori application 'Task Center' in Work Zone. Approval or rejection of invoices shall only be possible out of SAP Fiori application 'Task Center'.
- This functional specification is written based on the assumption that SAP does not provide new applications in future releases until go-live for parking outgoing customer invoices posted via the FI-AR module. The SAP roadmap for this process has been analyzed and no related item could be found. Should new Fiori applications be released by SAP to support this process in a more effective way and Syensqo decides to adopt those in its functional process designs, this functional specification may become obsolete or may require adjustments.

Security, Integrity and Controls

Accounts Receivable Processors (refer to '09.05.02.02. Post Sundry Debtor Invoices/Credit Memos' for more details on the role responsibilities) shall be given authorizations for the following tasks as part of the invoice entry process:

- Park AR invoice document
- Set status of parked documents to 'Saved as Completed'

- Delete parked AR invoice document
- Display parked AR invoice document

AR Invoice Approvers shall be granted authorizations to:

- Display parked AR invoice document
- Release/reject parked invoice document

Functional Restrictions:

Users must not be given authorizations to directly post a document in Fiori app 'FB70 - Create Outgoing Invoices'.

The agent determination table shall be maintained by IT via service requests and must remain editable in all systems of the S/4 HANA system landscape (=current setting) as HR positions may differ from system to system.

Special Requirements

Work item messages as well as custom error messages generated by the workflow need to be translated into the four core logon languages (English, French, Italian, Mandarin) defined for the SyWay program as endorsed in '[KDD055 - Multi-Language Support](#)'.

Design Rationale

Functional Requirements

The following enhancements/customizations will be required to cover all business requirements for the park/post workflow:

- Custom field to capture journal requestor:

To be able to differentiate between invoice requestor and invoice processor a new custom field needs to be created where the invoice processors are required to specify the user ID of the invoice requestor. This requirement will be covered and implemented via development request '[ERP-1749 Custom Field for AR and G/L Journal Workflow](#)'.

The workflow logic needs to check whether the user ID of the requestor and the user ID of the approver are matching. In case there is a match, the document should be automatically released/approved and subsequently posted.

- Lock document after submission for approval:

Once a document has been submitted for approval it shall no longer be editable until it gets approved or rejected by the reviewers/approvers. In case there are any changes required to the document, the document needs to be rejected by the approver to flow back to the processor to make the necessary changes.

- Add variables to workflow container and include them in the subject line/work item body text:

Some variables need to be added to the workflow container and eventually included in the subject line/work item body texts. The required variables are:

- Document Number: <VBKPF-BELNR>
- Invoice Number: <VBKPF-XBLNR>
- Company Code: <VBKPF-BUKRS>
- Fiscal Year: <VBKPF-GJAHR>
- Amount: <VBSEGD-WRBTR>
- Document Currency: <VBKPF- WAERS>
- Document Header Text: <VBKPF-BKTXT>
- GBU: Derive from profit center standard hierarchy via profit center used in highest-value line item.
- Profit Center: <VBSEGS-PRCTR>
- Profit Center Description: <CEPC-LTEXT>

If multiple profit centers are used in one invoice, the profit center from the line item with the highest LC2 value shall be selected.

- Approval levels and agent determination logic

All FI-AR sundry invoices parked in the system shall be subjected to the below approval levels and agent determination logic via custom config table:

- All invoices are subject to a mandatory review by the tax team. This is required as the invoice entry application does not have automatic tax code determination capabilities and relies on manual selection by the user which is prone to errors without proper understanding of the tax legislations in the respective countries.
- The second level of review and final approval of the invoice is only required if the invoice exceeds a certain threshold amount. Any invoices below the defined threshold amounts shall be auto-approved and posted immediately.

Level	Region	Country	Company Code	Amount (EUR)	HR Position	Band
1	*	*	*	-	Tax Accountant or job equivalent	C

2	*	BE	*	>=1000.00	Country Accounting Manager or job equivalent	D
---	---	----	---	-----------	---	---

Note:

- The threshold amounts are maintained in EUR for all company codes. The processing logic should compare the amounts in the agent determination table against the group currency amounts specified in the invoice document.
- Columns Region, Country and Company Code should be optional. Wildcard entries (*) should be possible for all three columns.
- All columns should be considered key fields. Multiple HR positions or bands may be assigned to a specific combination of row attributes.
- The dimensions region/country/company code shall be considered from most specific to least specific by the determination logic. The following order shall be followed (from most specific to least specific):

- 1.) Company Code
- 2.) Country
- 3.) Region

Example:

- In the custom config table, an entry is maintained at level 2 for country BE (Belgium) and amount >=1,000.00 EUR assigned to HR position 'S01'. Another entry is maintained for company code 1000, which is an entity operating in Belgium, and amount >=1,000.00 EUR and assigned to HR position 'S02'. If an invoice gets parked in the system for entity 1000 with an amount of 1,000.00 EUR, the approver determined at level 2 should be the user assigned to position 'S02' not 'S01'.

Level	Region	Country	Company Code	Amount (EUR)	HR Position	Band
1	*	*	*	-	T01	-
2	*	BE	*	>=1000.00	S01	-
2	*	BE	1000	>=1000.00	S02	-

- Region and country should be determined based on the country of the legal entity (T001-LAND1).
- The approver positions specified in the decision tables are member of the regional GBS teams. It is not expected to have region-specific or even country-specific positions in the future organization chart design so identifying the correct reviewers/approvers for a particular company code based on the HR position alone may not be sufficient. It may be required to look up the approver's regional or country responsibilities based on attributes defined in the authorization roles or user profiles. Legal entity responsibilities in GBS can spread across multiple countries within a region so the company code maintained in the employee master record of the approver may not be indicative enough of the actual legal entity responsibilities within GBS.
- It may also be required in some cases to define bands instead of HR positions in the decision table if certain positions are not available in a specific region/country/company code.
- **An additional custom check needs to be implemented to ensure that invoices requested by a final invoice approver are exempted from the 2nd level review.**

- Notifications to invoice requestor and invoice processor:

Notifications shall be sent out to the invoice requestor and invoice processor once requested invoices have been approved and posted in the system.

Subject Line: 'Sundry Customer Invoice <BELNR>/<BUKRS> requested by you was posted successfully'.

Body Text:

'Sundry Customer Invoice <BELNR>/<BUKRS> requested by you was posted successfully. Invoice details are as follows:

- Document number: <VBKPF-BELNR>
- Company Code: <VBKPF-BUKRS>
- Fiscal Year: <VBKPF-GJAHR>
- Amount: <VBSEGD-WRBTR>
- Document Currency: <VBKPF- WAERS>
- GBU: Derive from profit center standard hierarchy via profit center used in highest-value line item.
- Profit Centre: <VBSEGS-PRCTR>
- Profit Center Description: <CEPC-LTEXT>
- Document Header Text: <VBKPF-BKTX>

- Notifications to invoice processor:

The work item shall be routed back to the invoice processor in case errors are encountered during background processing of the invoice after initial approval of the document by the invoice approver. The following message shall be output:

Subject line: Sundry Customer Invoice <BELNR>/<BUKRS> contains errors – action required.

Body Text:

'Sundry Customer Invoice <BELNR>/<BUKRS> raised by you contains errors. The following errors were encountered:

<Error Message 1>

<Error Message 2>

Perform the necessary corrections and re-submit the invoice for approval.'

- Approval/Rejection via Fiori application 'Task Center'

SAP standard Fiori application 'Task Center' shall be the user interface used for approving/rejecting parked invoices. An additional enhancement may be required to enable usage of 'Task Center' for this park/post workflow.

- Substitution of user ID in document header:

The user ID of the invoice approver shall be substituted into the document header (BKPF-USNAM) once the document has been approved and posted successfully. This is needed to enable easy identification of the approvers for follow-ups if audit queries arise.

- Integration with EDICOM for e-invoicing:

Per regulatory requirement for Argentina (**RR-1108**), the outgoing FI-AR invoice has to be sent electronically to the government portal before being posted as accounting document. This requires an additional enhancement to the workflow in order to intercept the invoice document and send it to **Edicom** (e-invoicing service provider) for government validation.

- Fiori push notifications are required for this workflow:

The following Fiori push notifications shall be sent to by the workflow templates:

- Notification to approver once document got 'saved as completed' (Standard WF behavior for the approval work items)
- Notification to requestor once document got rejected by approver
- Notification to requestor and processor once document got posted by approver

Configuration Requirements

The activation of the workflow shall be controlled via assignment of a workflow variant to the company code only. No further configuration will be made. Regardless of the document type used for the invoice documents, the workflow should always be triggered upon saving a document as completed. This can be done via IMG activity Financial Accounting Financial Accounting Global Settings Global Parameters for Company Code Enter Global Parameters. Field to be checked against is T001-WFVAR.

SAP Standard Workflow

A custom workflow template variant shall be copied using a SAP standard workflow template as a reference to meet the business and process requirements and shall be activated via the necessary configurations specified above:

WS10000051 - Main workflow template to release parked invoice documents.

WS10000053 - Sub-workflow template for two-tier approval of invoice documents.

Functionally, these standard workflow templates activate a workflow messaging to the approvers once a document has been parked in the system. The standard workflow template does not lock the document once it has been submitted for approval. It can be re-submitted multiple times which leads to data inconsistencies in the approver's inbox.

Furthermore, the standard workflow template triggers the workflow notification upon initial parking of a document in the system. At parking stage, the system doesn't perform thorough data integrity checks hence technically incomplete documents can be routed for approval potentially leading to a high number of rejections and documents in error.

Standard workflow templates also do not notify the requestor once a document has been approved and posted. A notification shall be sent to the requestor of the invoice once requested documents have been successfully posted in the system.

As SAP standard workflow templates do not issue error notifications to either the requestor or the approver, further enhancements are required to enable such (push) notifications.

SAP standard also doesn't support agent determination based on LC2 amounts (group currency) which is required to simplify the global threshold definitions across all Syensqo entities. It also doesn't support routing of invoices based on the new organizational chart designs introduced as part of the SyWay program.

Subject line and work item text also require additions (e.g. include Profit Center in subject line) which is not foreseen nor supported by SAP standard workflow templates.

Triggers and Start Conditions

The workflow shall be triggered once a document gets successfully 'Saved as completed' by the invoice processor. Users may directly press the 'Save as completed' button rather than parking the document first and saving it as completed in a separate step so the workflow shall be triggered upon saving the document as completed regardless of whether it has been parked in a preceding step or not.

Approvers/Reviewers shall not be given editing rights to the source document. Any changes to the document must be performed by the invoice processor to achieve clear segregation of duties.

Parked documents for sundry customer invoices will all be created via Fiori application 'FB70 - Create Outgoing Invoices'.

Below a list of business objects that can be used for this workflow process:

Business Object	Event	Condition	Design Rationale Reference
FIPP	PreIPostingDocument.Completed	Parked document is saved as completed.	This event shall trigger the workflow.
FIPP_SUBWF02	Two-Level Amount Release	Parked document relevant for two-tiered approval workflows	
FIPP	PreIPostingDocument.Created	Parked document is created / changed	This event should not trigger the workflow.
FIPP	PreIPostingDocument.Deleted	Parked document is deleted	

Process Overview

1.) Business Scenario for regular invoices/credit memos:

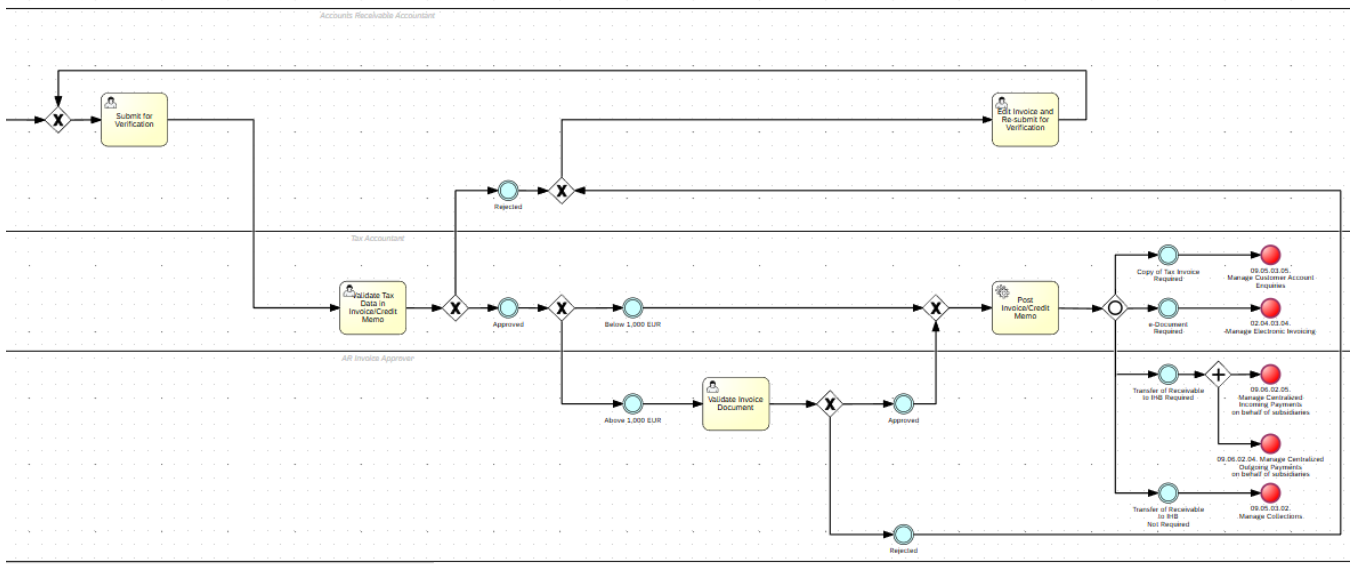

- AR Invoice Processor (initiator) parks the document.
- Workflow is triggered on 'Completed' event (document must be showing status 'Saved as Completed' to trigger workflow).
- A maximum of 2 approvals tiers are required for all documents. For low-value invoices, a single tier review and approval by the tax team is sufficient.
- A SAP Inbox notification will be sent to the reviewer/approver.
- Invoice gets either approved or rejected by the approver.
- When rejected, the document flows back to the processor for further adjustment and re-submission.
- When approved, the document shall be posted in the background. A notification shall be sent out to the requestor's and processor's inbox in SAP that the document has been approved and posted.

2.) Business Scenario for Argentina e-Invoicing:

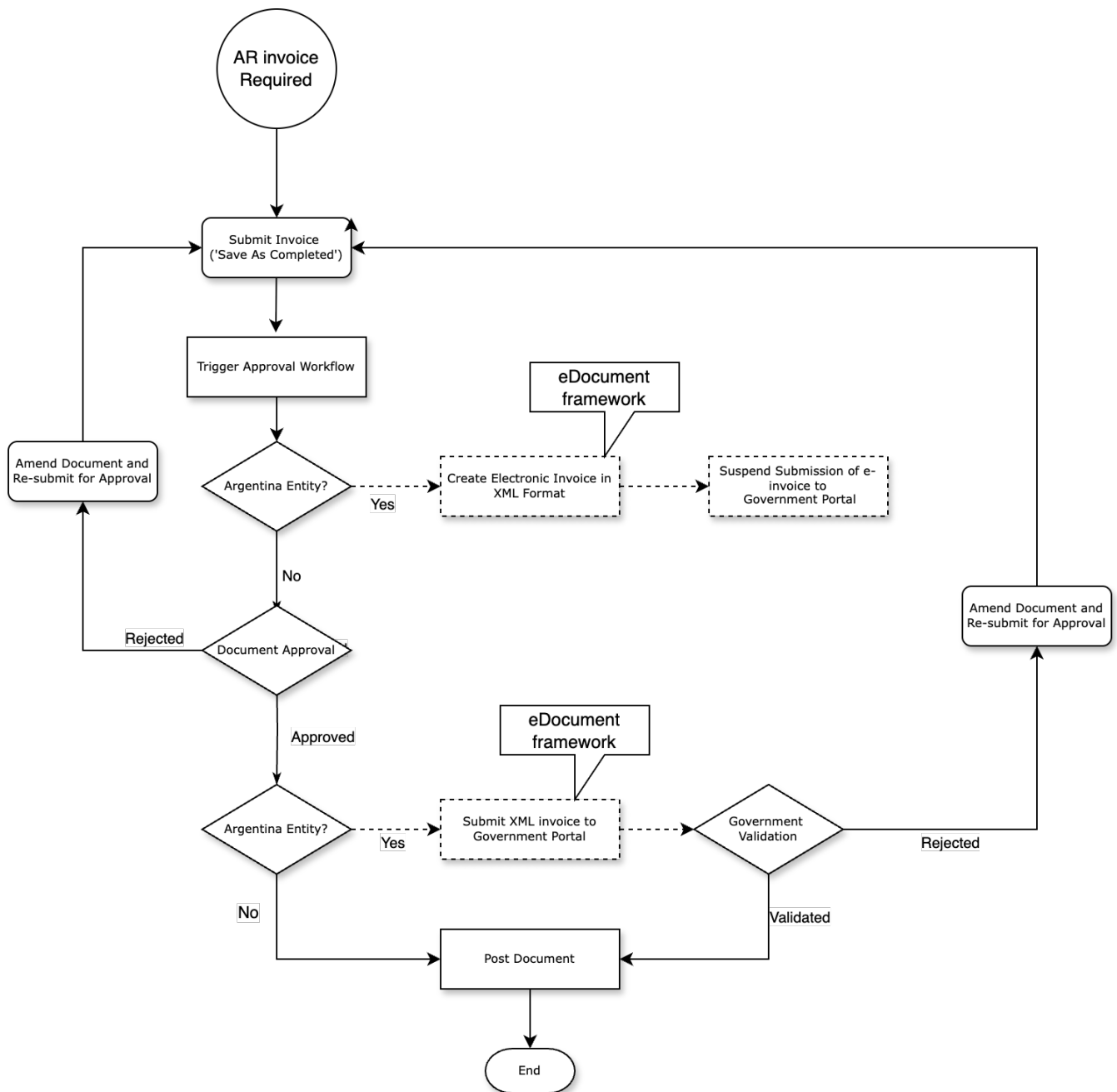

- AR Processor (initiator) parks the document.
- Workflow is triggered on 'Save as Completed' event (document must be showing status 'Saved as Completed' to trigger workflow). E-invoice shall be generated via the eDocument framework (ERP-728) but submission to the government portal for validation shall be suspended until the document has obtained internal approval.
- SAP 'Task Center' Inbox notification will be sent to the approver.
- If the company code is not an Argentina-based entity, invoice is either approved or rejected by the reviewers/approvers and subsequently posted or returned back to the processor for edits and re-submission.
- If the company code is an Argentina-based entity, once approved the e-document XML shall be sent to the Argentina government for validation via the EDICOM e-invoicing portal.
- If the validation by the government portal fails, the document flows back to the AR processor for further adjustment and re-submission
- If successfully validated by the government portal validation, the document shall subsequently be posted in the background.
- Once posted, a notification shall be sent out to the AR processor's and AR requestor's inbox in SAP that the document has been posted.

Workflow Steps

Step Description	Validate Document
Step Type	Decision Step

Approve / Reject texts and actions (for user decision steps)	<p>Two buttons are required for this decision step:</p> <ol style="list-style-type: none"> 1. <u>Approve:</u> <ul style="list-style-type: none"> o Submitted document should be posted automatically in the background (same behavior as if it was released via SBWP using the classic workflow framework). o Notify requestor and processor that document has been approved and posted. 2. <u>Reject:</u> <ul style="list-style-type: none"> o Document should be routed back to the journal processor. o Rejection reason must be entered and visible to processor in work item. o Work item needs to be visible in processor's Fiori inbox. Rejection reason/comments must be available under 'Comments' or 'Attachments' section in the work item message
Subject Text (Work Item Text)	Release Sundry Customer Invoice Document <BELNR><BUKRS>
Body Text (Task Description)	<p>'Sundry Customer Invoice <document number> raised in company code <company code> requires your action. Please validate the invoice entry, tax details and supporting documents to take the necessary actions.'</p> <ul style="list-style-type: none"> • Document number: <VBKPF-BELNR> • Company Code: <VBKPF-BUKRS> • Fiscal Year: <VBKPF-GJAHR> • Amount: <VBSEGD-WRBTR> • Document Currency: <VBKPF- WAERS> • GBU: Derive from profit center standard hierarchy via profit center used in highest-value line item. • Profit Centre: <VBSEGS-PRCTR> • Profit Center Description: <CEPC-LTEXT> • Document Header Text: <VBKPF-BKTX>
Possible Approvers (Possible Agents)	The agent determination should follow the logic as outlined in section 'Functional Requirements' of this functional specification document.
Approver Selection (Selected Agents)	<p>The selection of the right reviewing approving agent out of the pool of possible approving agents shall be facilitated by checking the regional responsibility of the designated reviewers/approvers.</p> <p>In case no approver can be found at the corresponding level for a given position or band in the approval matrix, the approvers shall be determined from the next level upwards based on the entry level position following the reporting lines defined in organizational chart structures.</p>
Escalation	Not applicable.
Email Notification	No email notification required. Only internal SAP message to approver's inbox is required.
Attachments	<p>The list of attachments shall include the supporting documents attached by the user to the invoice document subject to approval.</p> <p>A link to the parked document shall also be provided to allow the user to review the document in S/4 in document entry view (link to transaction code FV53).</p>

Error Handling

Should there be any errors returned by the workflow processing logics at agent determination stage, the standard daily workflow monitoring process for all workflow developments built as part of the SyWay program team for business-as-usual operations post go-live shall be followed. ~~a notification should be sent to the workflow administrator to perform follow-up actions.~~

The work item shall be routed back to the invoice processor in case errors are encountered during background processing of the invoice after initial approval of the document by the tax reviewer or the invoice approver. At the same the invoice document should be unlocked to be able to perform the necessary corrections before re-submission.

All error messages generated by or encountered by the workflow during background processing must be easily understandable to facilitate effective trouble-shooting and must be accessible via the workflow logs.

Deadline Monitoring

Deadline monitoring is not active for parked document approval workflows. Backlogs of parked documents in the system which are still awaiting release will be cleared out at the end of every month as part of the period-end closing activities. SAP has standard reports available to monitor outstanding parked documents.

Substitution/Forwarding/Reserving

Forwarding of workflows for the approval of parked documents is permitted. Forwarding should only be possible to approvers of the same HR level or above. It is the responsibility of the user to forward the work item to a person with sufficient authorizations to post in the company code of the invoice document.

Substitutions will be used especially in cases where users are on leave. The substitution rules should only allow for routing of the work item to a proxy of the same HR position/rank. The substitution rules should follow the rules and principles defined in the SoD principles introduced as part of the SyWay program.

Dependencies & Constraints

- Usage of the approval functions in 'Task Center' on mobile, handheld devices shall follow the overall guidelines of the UI strategy defined for the SyWay program.
- Dependency on custom development for e-invoicing solution for Argentina.
- The custom development 'ERP-1749 Custom Field for AR and G/L Journal Workflow' adds a custom field to capture the invoice requestor's user ID which the workflow needs to consider in the agent determination logic.

Volumetrics

The expected volume of customer invoices subjected to this workflow is low. The primary reason for this is that the sundry customer invoice processing via FI-AR is only resorted to in exception cases in the SyWay process designs. The primary route for customer invoices remains the billing process via the Sales and Distribution module, also in S/4 HANA.

Testing

How to Test

The testing of this workflow needs to be conducted when the standard workflow has been enhanced to meet the specified functional and business process requirements.

Some temporary assignments in the user decision table will be required for agent determination.

All invoice documents shall be parked via Fiori application 'FB70 - Create Outgoing Invoices'.

Consult the functional consultant to receive a sample invoice document that can be used as reference invoice document for mass testing purposes.

Test Conditions and Expected Results

ID	Condition	Expected Result
1	Define threshold for level 2 approval at 1,000 EUR. Create parked documents with different \$ amount specifications and check if workflow levels get triggered correctly.	Workflow is assigned to all parked document upon completion only. Workflow task to release the parked document is triggered. Work item is available in 'Task Center' of nominated reviewers/approvers. Work item is available in push notification of nominated reviewers/approvers.
2	Approve parked document from 'Task Center' (For Company Codes in other countries except Argentina)	Workflow task to release parked document is complete, document gets posted and work item list in 'Task Center' gets updated. Notification shall be sent out to requestor and processor that document got posted.
3	Reject parked document from 'Task Center'	Workflow task to reject/release parked document is complete; 'Task Center' worklist gets updated. No further workflow tasks are generated.

4	Lock parked document	<p>Workflow is assigned to the parked document.</p> <p>Workflow task to release the parked document is triggered.</p> <p>Changes to document shall be locked until document gets released through action from final approver (either rejection or approval).</p>
5	Select multiple parked documents in 'Task Center' and complete approval.	<p>Multi-selection of work items and mass approval is possible in the application.</p> <p>Workflow tasks to approve selected parked documents are complete and disappear from the user's work list in 'Task Center'.</p>
6	<p>Assign your own user ID as final approving agent and enter your own user ID as journal requestor in the invoice document.</p> <p>Ensure other user ID is assigned to HR position representing next higher level in authorization matrix.</p>	Agent determination logic should skip second level approval as requestor and approver are identical.
7	Assign an HR position as final approver. Make sure the HR position is vacant. Also ensure that other user ID is assigned to one-up HR position that the base position from the decision table reports into.	Agent determination logic should route the journal to the approver's manager instead as HR position of designated approver is currently vacant.
7	Post parked document via SWIA (back-up)	<p>Workflow task is completed (Posted).</p> <p>'Task Center' is updated (work item disappears from approver's work list).</p>
8	Reject parked document via SWIA (back-up)	<p>Workflow task is completed (Rejected).</p> <p>'Task Center' is updated (work item disappears from approver's work list).</p>
9	<p>Test process and workflows with alternate logon languages:</p> <p>Chinese</p> <p>French</p>	Workflow tasks can be processed in either of the four logon languages and the content of the message is free of spelling and grammar mistakes.
10	Approve journal with your own user ID.	User ID of approver shall be stored in BKPF-USNAM once document got posted.
11	Maintain multiple positions at L2 for country BE in the decision table. Park journal in 1010 with a value of more than 1k EUR. Check if invoice is routed to all legit approvers of company code 1010.	Invoice should be routed to all L2 approvers maintained in decision table which are responsible for entity 1010.
12	Maintain band E as L2 approver for all invoices beyond 1,000 EUR in value for region EMEA (no country & company code). Park invoice in entity 1010 with a value of more than 1,000 EUR. Check if invoices is routed to all legit approvers holding band E as per org chart design and responsible for entity 1010 within GBS.	Check if invoice is routed to all users holding band E positions and responsible for entity 1010 within GBS at level 2.
13	Maintain multiple (different) positions at L1 and L2 for region EMEA, country BE and company code 1010. Park invoice amounting to 1,100 EUR in company code 1010 and post 2 offsetting line items to two different profit centres belonging to entity 1010. One line item should be posted with a value of 600 EUR, the other 500 EUR. Check if invoice is routed to all legit approvers of the respective legal entity	<p>The most specific entry in the agent determination decision table should take precedence over the less specific entries. As such the user assigned to the position maintained at company code level (most specific) should be selected by the agent determination logic.</p> <p>In the work item text, check that the description of the highest-value profit centre is displayed.</p>
14	Maintain multiple HR positions for region EMEA as L1 approvers. At least one HR position maintained should have responsibilities outside of country Belgium. As threshold value for level 2 maintain 1,000 EUR. Park invoice worth less than 1,000 EUR in entity 1010.	Invoice should be sent to the right tax reviewer responsible for country Belgium. Do not send invoice for review to tax reviewers if they are not responsible for Belgium. Once reviewed by L1 approver, invoice should be posted right away.

15	<p>Reject invoice at L1, make the necessary changes and re-submit it for approval.</p> <p>Reject the same invoice at L2 and then subsequently re-submit it for approval.</p> <p>Approve the invoice.</p>	<p>Invoice needs to be routed for approval to the correct L1 approver. Upon rejection, it needs to flow back the invoice processor. Push notification must be sent to invoice processor.</p> <p>Invoice processor re-submits the invoice for approval, L2 approver rejects it again. Work item needs to flow back to the invoice processor. Push notification must be sent to invoice processor.</p> <p>Invoice processor re-submits the invoice for approval, L2 approver approves the invoices. Push notification sent to invoice processor and invoice requester that invoice was posted.</p>
16	<p>Approve parked document from 'Task Center' -</p> <p>Argentina government validation is <i>rejected</i></p> <p>(Company Codes is in Argentina)</p>	<p>Workflow cross checks the government rejection validation indicator to prevent the release of parked document and releases parked document editing lock, parked document is not posted and work item list in 'Task Center' gets updated.</p> <p>Notification shall be sent out to requester that document did not get posted due to Argentina government validation got rejected.</p>
17	<p>Approve parked document from 'Task Center' -</p> <p>Argentina government validation is <i>accepted</i></p> <p>(Company Codes is in Argentina)</p>	<p>Workflow cross-checks the government acceptance validation indicator to release parked document, after which document gets posted and work item list in 'Task Center' gets updated.</p> <p>Notification shall be sent out to requestor and processor that document got posted.</p>
18	<p>Reject parked document from 'Task Center' -</p> <p>Argentina government validation is <i>accepted</i></p> <p>(Company Codes is in Argentina)</p>	<p>Workflow cross checks the government acceptance validation indicator and 'Task Center' rejection after which document does not get posted and work item list in 'Task Center' gets updated.</p> <p>Notification shall be sent out to requestor and processor that document did not get posted because of rejection from approver.</p>
19	<p>Reject parked document from 'Task Center' -</p> <p>Argentina government validation is <i>rejected</i></p> <p>(Company Codes is in Argentina)</p>	<p>Workflow cross checks the government rejection validation indicator and 'Task Center' rejection after which document does not get posted and work item list in 'Task Center' gets updated.</p> <p>Notification shall be sent out to requestor and processor that document did not get posted because of rejection from approver and government rejected.</p>
20	<p>Check if parking of customer invoice is possible.</p>	<p>Parking of invoice documents must be possible. However, it must not trigger the approval workflow.</p>
21	<p>Check if deletion of customer invoice is possible.</p>	<p>It must be possible for the invoice processor to delete a parked invoice document that has not been submitted for approval yet or a parked invoice document that got rejected by the approval workflow /government validation.</p>
22	<p>Check if direct posting is possible via Fiori app 'FB70 - Create Outgoing Invoices'</p>	<p>The direct posting of invoices via the invoice entry application is not permitted and must be suppressed.</p>
23	<p>Switch on substitution for workflow.</p>	<p>Only users from same rank or higher rank positions should be selectable.</p>
24	<p>Forward work item to other user.</p>	<p>Only users from same rank or higher rank positions should be selectable.</p>

Test Considerations/Dependencies

- All master data and configurations for posting General Ledger journals in the system must be set up in the test system.

Other Information

Development Details

Package

Package Name	Parent Package

Workflow Implementation

UI Type	UI Name	Fiori Catalogue	Design Rationale Reference

Other Development Objects

Object Type	Object Name	Purpose/High Level Logic	Design Rationale Reference

Appendix

See also

File	Modified
File Process Flow Argentina e-invoicing AR Sundry Invoice draw.io diagram	Jan 08, 2026 by WEINERT-ext, Patrick
File -Process Flow Argentina e-invoicing AR Sundry Invoice.tmp draw.io Draft	Jan 08, 2026 by WEINERT-ext, Patrick

[Download All](#)

Change log

Version	Published	Changed By	Comment
CURRENT (v. 59)	Feb 06, 2026 05:33	BECHTER-ext, Alex	
v. 58	Feb 02, 2026 02:24	BECHTER-ext, Alex	
v. 57	Jan 29, 2026 11:00	WEINERT-ext, Patrick	
v. 56	Jan 29, 2026 10:55	BECHTER-ext, Alex	
v. 55	Jan 08, 2026 10:23	WEINERT-ext, Patrick	
v. 54	Jan 07, 2026 07:42	BECHTER-ext, Alex	

v. 53	Jan 07, 2026 07:32	BECHTER-ext, Alex
v. 52	Jan 07, 2026 07:21	BECHTER-ext, Alex
v. 51	Jan 06, 2026 09:41	BECHTER-ext, Alex
v. 50	Dec 19, 2025 06:02	BECHTER-ext, Alex

[Go to Page History](#)

Workflow history

This view shows the 5 most recent entries. The complete workflow log is available from the 'Document Activity' menu item.

Mar 06, 2026	Actor	Type	Activity	Version
Approved	 BOUMSSAHAL-ext, Mohamed	State	changed state to Approved at 12:40 pm	v59
Lead Approval	 BOUMSSAHAL-ext, Mohamed	State	gave <i>POD Lead Review</i> approval at 12:40 pm	
Feb 06, 2026				
	WEINERT-ext, Patrick	State	changed expiry date to '13 Feb, 2026 05:45 am' at 5:45 am	
		State	changed state to Lead Approval at 5:45 am	v59
Tech Review	WEINERT-ext, Patrick	State	gave <i>Tech Review</i> approval at 5:45 am	
From Dec 16, 2025 to Feb 06, 2026				
	ASMI-ext, Arsalan Ahmad , BECHTER-ext, Alex and WEINERT-ext, Patrick	Edit	multiple updates from  ASMI-ext, Arsalan Ahmad ,  BEC WEINERT-ext, Patrick	