

Application Architecture Vertex

Status	Approved
Owner	RUFFINONI, Francois CABELLO MARTOS-ext, Gabino
Stakeholders	Marcela Anido, Jean Andrade
LeanIX Link	Vertex Cloud

Introduction

Scope & Objectives

This document aims at describing the overall architecture of Vertex application in the SyWay context.

As per [KDD093](#), SyWay will run Vertex Cloud solution (SaaS).

Key Decisions and Requirements

Description	Rationale
Vertex Hosting	Following KDD093 , Vertex Cloud is the solution
Vertex Cloud runs in EU region	Closer to S/4HANA for performance reason Following the overall hosting approach to host RoW applications in EU
Connected to S/4HANA RoW instance only	Vertex is primarily used for US tax calculations and thus is not required for China

Terminology

VERTEX is an external software used by Syensqo to calculate taxes on customer and vendor invoices for US and Canadian legal entities. Tax Rules are customized by legal entities in VERTEX, based on Syensqo's Sales and Procurement processes. The tax rules customized in VERTEX are based on directions from the Syensqo USA Tax Department. Tax Jurisdiction Codes linked to the Country/State or Province/County/City/Postal Code are assigned to US and Canadian Customer and Vendor master data in SAP. Tax jurisdiction codes also are assigned to company codes, shipping points, and storage locations for the US and CA.

When a sales order, customer invoice/credit memo, purchase order, or vendor invoice/credit memo are processed in SAP, there is a Remote Function Call (RFC) from SAP to VERTEX to determine taxability of the transaction based on the customization. If the transaction is determined to be taxable, the tax rate is determined by the tax jurisdiction code specified on the customer, vendor, or plant/delivery address master record.

VERTEX issues monthly updates for tax rule changes, tax jurisdiction code changes, and tax rate changes. These monthly updates are applied to the VERTEX development, quality, and production servers to ensure tax calculations are correct.

Vertex Cloud is connected to its respective S/4 system through a component named SIC (SAP Interface Component).

Application Architecture

Overview

Today we have 6 SICs processes running in parallel for each ECC. This is for performance reason. We might review it later but we took the same initial design as target

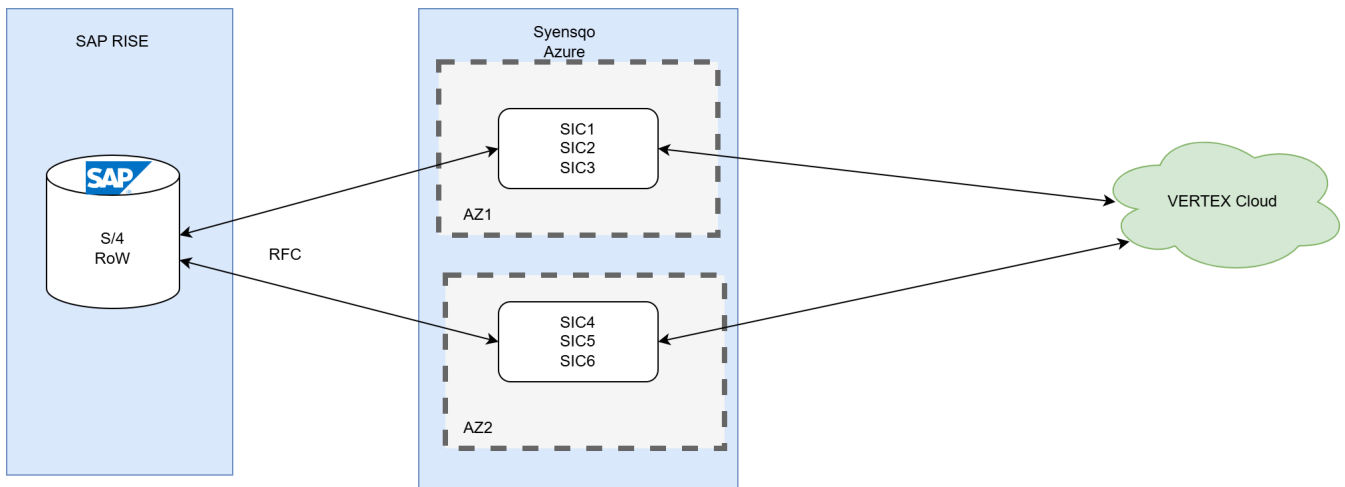

Application Architecture Components

Vertex runs in S/4 systems through standard processes and transactions. . There are however dedicated objects to help on configuration, customization, monitoring and tax management. This list will depend on the additional tools and features purchased by Syensqo and are provided as external transports.

A specific RFC in S/4 calls the SIC processes, passing the required information onto them. The request is then sent against Vertex Cloud. Data is retrieved by SIC and sent back to the calling S/4. It uses SAP Jco and a J2EE engine.

Vertex Cloud operates the tax calculation and other activities. Syensqo IT team and tax department need accesses to Vertex Cloud to configure and manage their specific activities.

Network Architecture

Users will access Vertex cloud via their normal internet access

There is no end-user access required for SIC (only IT)

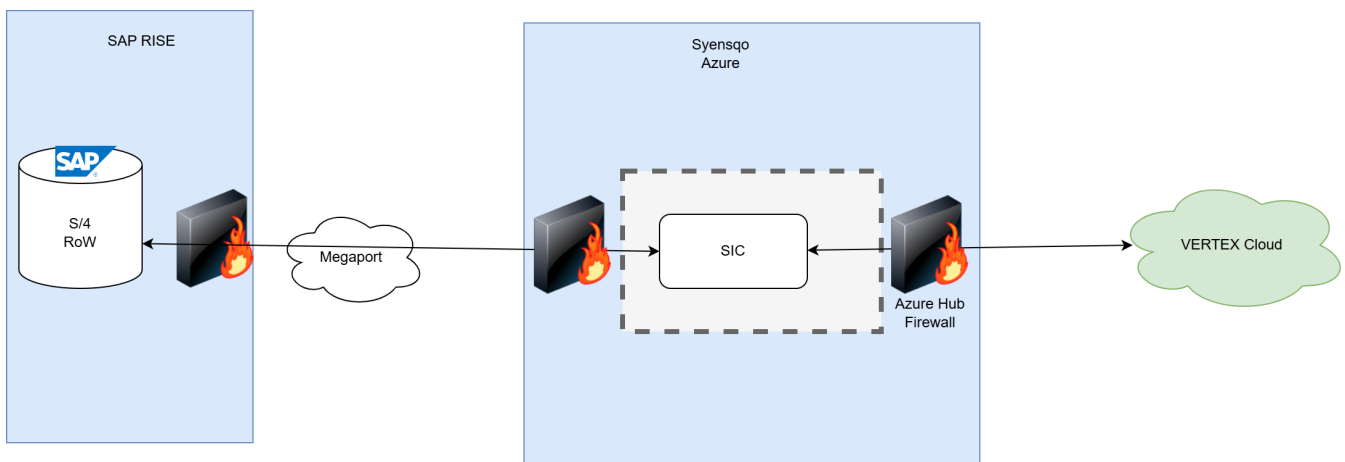

System Landscape

Vertex Cloud has 3 different environments : 1 for DEV, 1 for QAS, 1 for PROD. We will use different partitions (up to 4 available per instance) on Vertex Cloud to segregate the environments (Vertex partitions can be understood as the equivalent of an SAP client)

Syensqo will have 3 servers for running the SIC : 1 server serving as interface for all non-prods S/4 systems towards Vertex Cloud Dev and Qas. 2 servers in 2 differents AZ for production with multiple SIC running in parallel. It will provide HA and good response times.

The part residing in S/4 is for all S/4 RoW systems

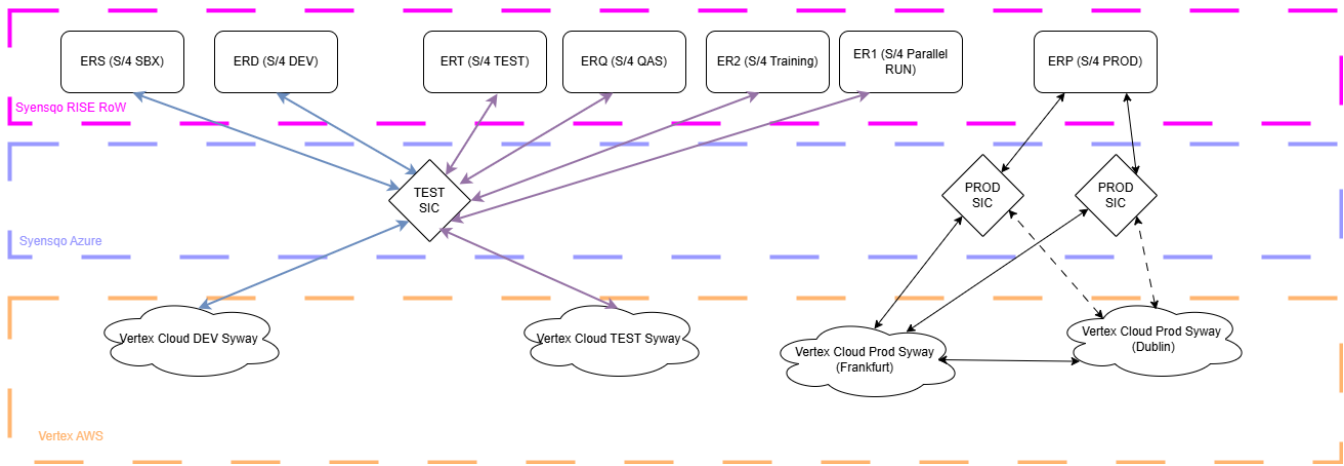

Hosting Details

Vertex Cloud will be hosted in AWS EU region.

Region	Localisation	Purpose	Infrastructure provider
EU	Frankfurt	Primary	AWS
EU	Dublin	DRP	AWS

Vertex SIC will run on Syensqo Azure on dedicated RedHat servers hosted in Azure Paris.

System Access

The main usage of Vertex is done in background from SAP. IT team and Tax department will connect to the web page to proceed with some specific activities related to configuration.

URLs for the DEV, QAS, and PROD instances of Vertex will be recorded here once the instances are provisioned.

Application Security

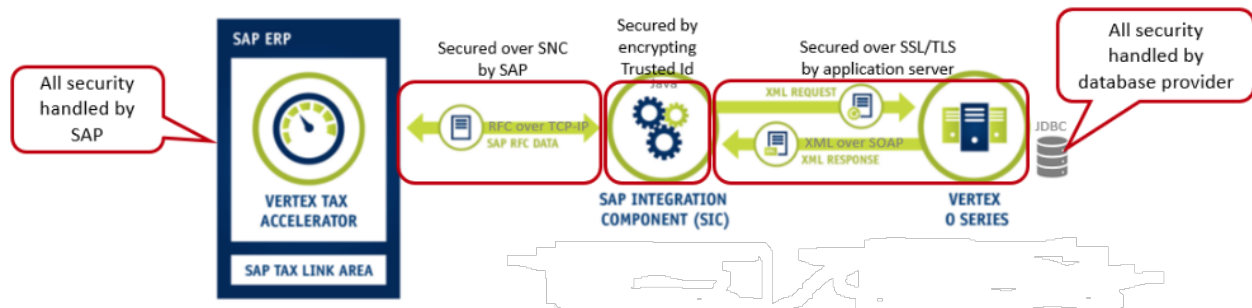

Authentication

Syensqo users will connect through SSO to Vertex Cloud

There is a dedicated technical account for the connection from SIC to S/4

Authorisation

Authorisations in S/4 will be provided depending on the user roles. This is not covered in this document.

Authorisations in Vertex Application will be managed manually by the different teams.

Communication Security

Communication between SICs and Vertex Cloud is encrypted (HTTPS)

Communication between SICs and S/4 must be set as RFC with SNC encryption

Data Security

Credentials and TrustedIDs must be encrypted in SIC configuration file.

We shall enable the use of Trusted IDs and assign each partition to a Trusted ID. Trusted IDs do not allow anyone unauthorized to log on to our system to change our tax data.

A Trusted ID is a partition-specific unique identifier that enables a secure connection where messages are exchanged between Vertex cloud products and an external system.

A partition represents a logical separation of data that is isolated from other logical data sets.

- Each logical data set can be associated with a single entity or with multiple entities in a single system.
- Multiple taxpayers can use the same partition.

Operation Architecture

Change and Configuration Management

Changes on S/4 will follow S/4 change management (see [Transport Management for Release 4 DD-TEC-170](#))

Changes on SIC must be tested against the different non-productions environments and validated before proceeding with the production implementation.

Changes on Vertex Cloud must be tested and validated in DEV then QAS.

There is no tool to transport the changes between the different environments (SIC and Cloud), they have to be manually reproduced each time.

Monitoring

Monitoring of Vertex Cloud is part of Vertex contract. Different levels of support (Gold/Silver/Normal) and reactivity can be defined. SyWay selected the normal standard plan.

Vertex Cloud status can be checked [here](#).

Monitoring of the SIC servers is done as other VMs in Azure (see [Network and Infrastructure Architecture DD-TEC-070](#))

Sizing

Sizing of production is based on current O Series

Sizing of SIC servers depends on the number of SIC processes running. It is foreseen to use 3+3 SICs processes in parallel for production.

The hardware requirements are described below (see best recommendations)

Configuration item	Minimum requirement	Better recommendation	Best recommendation
CPU	64-bit 2 core processor	64-bit 4 core processor	64-bit 4 core processors
Storage	10 GB	50 GB	100 GB
RAM	8 GB	16 GB (DDR4+)	32 GB (DDR5)
Network Connection	100BaseT or equivalent	1+ Gbps or equivalent	1+ Gbps or equivalent

High Availability & Disaster Recovery

SLA is 99.9% and obtained via Vertex Cloud running on 2 different regions in EU (Primary is AWS Frankfurt with secondary in AWS Dublin)

SIC servers are deployed on 2 availability zones in Azure in order to achieve HA. All SICs processes register against the same RFC destination in S/4

Predefined SIC configuration files to address the DRP Vertex Cloud must be prepared and manually started in case of Vertex Cloud failover

Backup/Restore

Backups and restore are managed by Vertex in order to meet (or exceed) the below RPO/RTO

Cloud-based Services delivered via Cloud	
RPO	4 hours
RTO	4 hours

On the SIC server part, backups are scheduled following the Azure global backup strategy (see [Azure Backup Policy](#))

Maintenance Plan

Vertex reserves a weekly recurring scheduled maintenance each sunday between 12AM and 6AM ET. Scheduled Maintenance windows will be published at least 72 hours in advance in the status [page](#) . Shorter publication period may however apply if a maintenance is required for security reasons.

SIC servers will follow standard Azure patching cycle. Update to SIC component itself will be done on demand.

Exceptions

See also

File	Modified
PDF File Approval by Frank - 2026-03-30.pdf	Mar 30, 2026 by WENNINGER-ext, Sascha
PDF File Stakeholder endorsement deemed after closure of all comments.pdf	Mar 23, 2026 by WENNINGER-ext, Sascha

File Vertex landscape draw.io diagram	Mar 18, 2026 by RUFFINONI, Francois
File Vertex network draw.io diagram	Feb 24, 2026 by RUFFINONI, Francois
File Vertex Archi draw.io diagram	Jan 22, 2026 by RUFFINONI, Francois

[Download All](#)

Change log

Version	Published	Changed By	Comment
CURRENT (v. 47)	Mar 18, 2026 08:37	RUFFINONI, Francois	
v. 46	Mar 11, 2026 09:36	WENNINGER-ext, Sascha	
v. 45	Mar 04, 2026 10:05	RUFFINONI, Francois	
v. 44	Mar 04, 2026 10:02	WENNINGER-ext, Sascha	
v. 43	Mar 04, 2026 09:48	WENNINGER-ext, Sascha	
v. 42	Mar 04, 2026 09:42	WENNINGER-ext, Sascha	
v. 41	Mar 04, 2026 08:22	RUFFINONI, Francois	
v. 40	Mar 04, 2026 08:21	RUFFINONI, Francois	
v. 39	Mar 04, 2026 08:21	RUFFINONI, Francois	
v. 38	Feb 24, 2026 08:39	RUFFINONI, Francois	

[Go to Page History](#)

Workflow history

This view shows the 5 most recent entries. The complete workflow log is available from the 'Document Activity' menu item.

Mar 30, 2026	Actor	Type	Activity	Version
Approved	WENNINGER-ext, Sascha	State	changed state to Approved at 8:01 am	v47
Pending SteerCo Review	WENNINGER-ext, Sascha	State	gave <i>Final Approval</i> approval at 8:01 am <i>Approved by Frank Bolata. Email attached</i>	
Mar 23, 2026				
	WENNINGER-ext, Sascha	State	changed expiry date to '06 Apr, 2026 03:01 pm' at 4:01 pm	
		State	changed state to Pending SteerCo Review at 4:01 pm	v47
Pending Stakeholder Review	WENNINGER-ext, Sascha	State	gave <i>Stakeholder Review</i> approval at 4:01 pm <i>Endorsed after acceptance of all response to review comments. See attached email</i>	
		State	changed expiry date to '30 Mar, 2026 02:57 pm' at 3:57 pm	
		State	changed state to Pending Stakeholder Review at 3:57 pm	v47

Edited following DA
Endorsement

WENNINGER-
ext, Sascha

State

gave *Minor change* approval at 3:57 pm

minor diagram update
